

AXOR®

hansgrohe

DE	Montageanleitung	2
FR	Instructions de montage	2
EN	assembly instructions	3
IT	Istruzioni per Installazione	3
ES	Instrucciones de montaje	4
NL	Handleiding	4
DK	Monteringsvejledning	5
PT	Manual de Instalação	5
PL	Instrukcja montażu	6
CS	Montážní návod	6
SK	Montážny návod	7
ZH	组装说明	7
RU	Инструкция по монтажу	8
HU	Szerelési útmutató	9
FI	Asennusohje	9
SV	Monteringsanvisning	10
LT	Montavimo instrukcijos	10
HR	Uputstva za instalaciju	11
TR	Montaj kılavuzu	11
RO	Instrucțiuni de montare	12
EL	Οδηγία συναρμολόγησης	12
SL	Navodila za montažo	13
ET	Päigaldusjuhend	13
LV	Montāžas instrukcija	14
SR	Uputstvo za montažu	14
NO	Montasjeveiledning	15
BG	Ръководство за монтаж	15
SQ	Udhëzime rreth montimit	16
AR	تعليمات التجميع	16

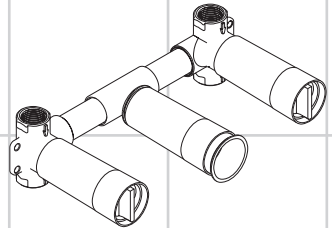

10303180



Sicherheitshinweise

- Bei der Montage müssen zur Vermeidung von Quetsch- und Schnittverletzungen Handschuhe getragen werden.
- Große Druckunterschiede zwischen den Kalt- und Warmwasseranschlüssen müssen ausgeglichen werden.

Montagehinweise

- Vor der Montage muss das Produkt auf Transportschäden untersucht werden. Nach dem Einbau werden keine Transport- oder Oberflächenschäden anerkannt.
- Die Armatur muss nach den gültigen Normen montiert, gespült und geprüft werden!
- Die Armatur muss isoliert und schallentkoppelt montiert werden.

Symbolerklärung



Kein essigsäurehaltiges Silikon verwenden!



Wandverstärkung notwendig



Teflonfaden



Montagebeispiele (siehe Seite 19)

Die Montagehöhe muss im Einzelfall dem Waschtisch individuell angepasst werden.



Maße (siehe Seite 18)



Serviceteile (siehe Seite 18)

Sonderzubehör (siehe Seite 18)

nicht im Lieferumfang enthalten



Dichtmanschette #96383000
Verlängerung 25 mm #96529000
Verlängerung 25 mm #95413000



Prüfzeichen (siehe Seite 36)

Montage
siehe Seite 17

Consignes de sécurité

- Lors du montage, porter des gants de protection pour éviter toute blessure par écrasement ou coupure.
- Il est conseillé d'équilibrer les pressions de l'eau chaude et froide.

Instructions pour le montage

- Avant son montage, s'assurer que le produit n'a subi aucun dommage pendant le transport. Après le montage, tout dommage de transport ou de surface ne pourra pas être reconnu.
- La robinetterie doit être installée, rincée et contrôlée conformément aux normes valables!
- La robinetterie doit être montée de façon isolée et insonorisée.

Description du symbole



Ne pas utiliser de silicone contenant de l'acide acétique!



Renforcement de la paroi nécessaire



Fil téflon



Exemples de montage (voir page 19)

La hauteur du montage peut être individuellement adaptée selon le besoin.



Dimensions (voir page 18)



Pièces détachées (voir pages 18)

Accessoires en option (voir page 18)

ne fait pas partie de la fourniture
lamelle #96383000

jeu de rallonge 25 mm #96529000

jeu de rallonge 25 mm #95413000

Classification acoustique et débit (voir page 36)





Montage
voir page 17





Safety Notes

-  Gloves should be worn during installation to prevent crushing and cutting injuries.
-  The hot and cold supplies must be of equal pressures.

Installation Instructions

- Prior to installation, inspect the product for transport damages. After it has been installed, no transport or surface damage will be honoured.
- The fitting must be installed, flushed and tested after the valid norms!
- The fittings must be mounted in an insulated manner and with sound insulation.

Symbol description



Do not use silicone containing acetic acid!



Area for required wall reinforcement



Teflon thread



Installation example (see page 19)

The installation height must be individually adjusted to the basin.



Dimensions (see page 18)



Spare parts (see page 18)

Special accessories (see page 18)

order as an extra



sealing foil #96383000
 extension 25 mm #96529000
 extension 25 mm #95413000





Test certificate (see page 36)

Assembly
see page 17



Indicazioni sulla sicurezza

-  Durante il montaggio, per evitare ferite da schiacciamento e da taglio bisogna indossare guanti protettivi.
-  Attenzione! Compensare le differenze di pressione tra i collegamenti dell'acqua fredda e dell'acqua calda.

Istruzioni per il montaggio

- Prima del montaggio è necessario controllare che non ci siano stati danni durante il trasporto. Una volta eseguito il montaggio, non verranno riconosciuti eventuali danni di trasporto o delle superfici.
- La rubinetteria deve essere installata, pulita e testata secondo le istruzioni riportate!
- Il rubinetto deve essere installato isolato e disaccoppiato dai rumori.

Descrizione simbolo



Non utilizzare silicone contenente acido acetico!



Campo rinforzo necessario della parete



Filo di teflon



Esempio di installazione (vedi pagg. 19)

L'altezza di montaggio deve essere adattata individualmente al lavabo.



Ingombri (vedi pagg. 18)



Parti di ricambio (vedi pagg. 18)

Accessori speciali (vedi pagg. 18)

non contenuto nel volume di fornitura



guarnizione a flangia #96383000
 Prolunga 25 mm #96529000
 Prolunga 25 mm #95413000



Segno di verifica (vedi pagg. 36)

Montaggio
vedi pagg. 17



Indicaciones de seguridad

- ⚠ Durante el montaje deben utilizarse guantes para evitar heridas por aplastamiento o corte.
- ⚠ Grandes diferencias de presión en servicio entre agua fría y agua caliente deben equilibrarse.

Indicaciones para el montaje

- Antes del montaje se debe examinarse el producto contra daños de transporte. Después de la instalación so se reconoce ningún daño de transporte o de superficie.
- El grifo tiene que ser instalado, probado y testado, según las normas en vigor.
- El grifo debe ser instalado con aislamiento y desacoplamiento acústico.

Descripción de símbolos



No utilizar silicona que contiene ácido acético!



Área refuerzo necesario de la pared



Hilo de teflón



Ejemplos de montaje (ver página 19)

La altura de montaje debe adaptarse individualmente al lavabo.



Dimensiones (ver página 18)



Repuestos (ver página 18)

Opcional (ver página 18)

no incluido en el suministro



Tira impermeabilizante #96383000
 Prolongación 25 mm #96529000
 Prolongación 25 mm #95413000



Marca de verificación (ver página 36)

Veiligheidsinstructies

- ⚠ Bij de montage moeten ter voorkoming van kniel- en snijwonden handschoenen worden gedragen.
- ⚠ Grote drukverschillen tussen de koud- en warmwatertoevoer dienen vermeden te worden.

Montage-instructies

- Vóór de montage moet het product gecontroleerd worden op transportschade. Na de inbouw wordt geen transport- of oppervlakteschade meer aanvaard.
- Leidingen doorspoelen volgens Norm. De mengkraan vervolgens monteren en controleren!
- De armatuur moet geïsoleerd en geluidsontkoppeld gemonteerd worden.

Symboolbeschrijving



Gebruik geen zuurhoudende silicone!



Wandversterking noodzakelijk voor montage



Teflondraad



Montagevoorbeelden (zie blz. 19)

De montagehoogte moet individueel aan de wastafel worden aangepast.



Maten (zie blz. 18)



Service onderdelen (zie blz. 18)

Toebehoren (zie blz. 18)

behoort niet tot het leveringspakket



dichtmanchet #96383000
 Verlengstuk 25 mm #96529000
 Verlengstuk 25 mm #95413000



Keurmerk (zie blz. 36)



Montage zie blz. 17



Sikkerhedsanvisninger

- △ Ved monteringen skal der bruges handsker for at undgå kvæstelser og snitsår.
- △ Større trykforskelle mellem koldt og varmt vand bør udjævnes.

Monteringsanvisninger

- Før monteringen skal produktet kontrolleres for transportskader. Efter monteringen godkendes transportskader eller skader på overfladen ikke længere.
- Ifølge gældende regler, skal armaturet monteres, skylles igennem og afprøves.
- Armaturet skal monteres isoleret og lydisoleret.

Symbolbeskrivelse



Der må ikke benyttes eddikesyreholdig silikone!



Område nødvendigvægforstærkning



Teflonråd



Monteringseksempler (se s. 19)

Installationshøjden skal tilpasses individuelt til håndvasken.



Målene (se s. 18)



Reserve dele (se s. 18)

Specialtilbehør (se s. 18)

ikke med i leveringsomfang



tætningsmanchet #96383000
Forlængersæt 25 mm #96529000
Forlængersæt 25 mm #95413000



Godkendelse (se s. 36)

Montering se s. 17

Avisos de segurança

- △ Durante a montagem devem ser utilizadas luvas de protecção, de modo a evitar ferimentos resultantes de entalamentos e de cortes.
- △ Grandes diferenças entre as pressões das águas quente e fria devem ser compensadas.

Avisos de montagem

- Antes da montagem deve-se controlar o produto relativamente a danos de transporte. Após a montagem não são aceites quaisquer danos de transporte ou de superfície.
- A misturadora deve ser instalada, purgada e testada de acordo com as normas em vigor!
- A torneira deve ser montada de forma isolada e desacoplada sonoramente.

Descrição do símbolo



Não utilizar silicone que contenha ácido acético!



Área reforçada necessária da parede



Fio de Teflon



Exemplos de montagem (ver página 19)

A altura de instalação deve ser individualmente ajustada ao lavatório.



Medidas (ver página 18)



Peças de substituição (ver página 18)

Acessórios especiais (ver página 18)

não incluído no volume de fornecimento
Disco de borracha #96383000
Crescente 25 mm #96529000
Crescente 25 mm #95413000



Marca de controlo (ver página 36)

Montagem ver página 17





Wskazówki bezpieczeństwa

- △ Aby uniknąć zranień, takich jak zgniecenia czy przecięcia, podczas montażu należy nosić rękawice.
- △ Znaczne różnice ciśnień na dopływach ciepłej i zimnej wody muszą zostać wyrównane.

Wskazówki montażowe

- Przed montażem należy skontrolować produkt pod kątem szkód transportowych. Po montażu nie widać żadnych szkód transportowych ani szkód na powierzchni.
- Armatura musi być zamontowana, przepłukana i wypróbowana według obowiązujących norm!
- Armaturę należy zaizolować i zamontować z izolacją dźwiękową.

Opis symbolu



Nie stosować silikonów zawierających kwas octowy!



Niezbędne wzmocnienie ścian



Nitka teflonowa



Przykłady montażowe (patrz strona 19)

Wysokość montażu musi zostać ustalona indywidualnie do każdej umywalki.



Wymiary (patrz strona 18)



Części serwisowe (patrz strona 18)

Wyposażenie specjalne (patrz strona 18)

Nie jest częścią dostawy
 Uszczelka mocująca #96383000
 Przedłużka 25 mm #96529000
 Przedłużka 25 mm #95413000



Znak jakości (patrz strona 36)

Montaż

patrz strona 17

Bezpečnostní pokyny

- △ Pro zabránění řezným zraněním a pohmožděním je nutné při montáži nosit rukavice.
- △ Je nutné vyrovnat velké rozdíly tlaku mezi přípoji studené a teplé vody.

Pokyny k montáži

- Před montáží je třeba produkt zkontrolovat, zda nebyl při transportu poškozen. Po zabudování nebudou uznány žádné škody způsobené transportem nebo poškození povrchu.
- Armatura se musí montovat, proplachovat a testovat podle platných norem!
- Při instalaci musí být provedena tak, aby byla baterie zaizolovaná a zvukotěsná.

Popis symbolů



Nepoužívat silikon s obsahem kyseliny octové!



nutné vyztužení stěny



Teflonové vlákno



Příklady montáže (viz strana 19)

V jednotlivých případech musí být montážní výška individuálně upravena podle umývadla.



Rozměry (viz strana 18)



Servisní díly (viz strana 18)

Zvláštní příslušenství (viz strana 18)

není součástí dodávky
 těsnící manžeta #96383000
 prodloužení 25 mm #96529000
 prodloužení 25 mm #95413000



Zkušební značka (viz strana 36)

Montáž

viz strana 17





Bezpečnostné pokyny

- △ Pri montáži musíte nosiť rukavice, aby ste predišli pomliaždeninám a rezným poraneniam.
- △ Velké rozdiely v tlaku medzi prípojkami studenej a teplej vody musia byť vyrovnané.

Pokyny pre montáž

- Pred montážou musíte produkt skontrolovať, či nebol počas transportu poškodený. Po zabudovaní nebudú uznané žiadne škody spôsobené transportom alebo poškodenia povrchu.
- Batéria sa musí montovať, preplachovať a testovať podľa platných noriem!
- Armatúra sa musí namontovať zaizolovaná s oddelením od hluku v pevných telesách.

Popis symbolov



Nepoužívať silikón s obsahom kyseliny octovej!



Potrebné zosilnenie steny



Teflónové vlákno



Príklady montáže (viď strana 19)

Montážna výška sa musí nastaviť samostatne podľa príslušného umývadla.



Rozmery (viď strana 18)



Servisné diely (viď strana 18)

Zvláštne príslušenstvo (viď strana 18)

nie je súčasťou dodávky
tesniaca manžeta #96383000
Predĺženie 25 mm #96529000
Predĺženie 25 mm #95413000



Osvedčenie o skúške (viď strana 36)

Montáž
viď strana 17



安全技巧

△ 装配时为避免挤压和切割受伤，必须戴上手套。

△ 冷热水管间过大的压力差必须予以平衡。

安装提示

- 安装前必须检查产品是否受到运输损害。安装后将不认可运输损害或表面损伤。
- 必须按照现行的规定安装，冲洗和测试产品！
- 龙头必须以静噪的方式独立安装。

符号说明



请勿使用含有乙酸的硅！



墙壁必要加强的区域



特氟龙线



安装示意 (参见第 19 页)

安装高度必须根据具体的浴盆进行调整。



大小 (参见第 18 页)



备用零件 (参见第 18 页)

选装附件 (参见第 18 页)

不在供货范围内



密封箔 #96383000
加长 25 mm #96529000
加长 25 mm #95413000





检验标记 (参见第 36 页)

安装
参见第 17 页



Указания по технике безопасности

-  Во время монтажа следует надеть перчатки во избежание прищемления и порезов.
-  донного клапа. Перед установкой смесителя необходимо регулировочными кранами выровнять давление холодной и горячей воды при помощи вентилей регулирующих подачу воды в квартиру.

Указания по монтажу

- Перед монтажом следует проверить изделие на предмет повреждений при перевозке. После монтажа претензии о возмещении ущерба за повреждения при перевозке или повреждения поверхностей не принимаются.
- Смеситель должен быть смонтирован по действующим нормам и в соответствии с настоящей инструкцией, проверен на герметичность и безупречность работы
- Арматура должна монтироваться изолированно и со звуковой защитой.

Описание символов



Не применяйте силикон, содержащий уксусную кислоту.



Необходимо усиление стены



Тефлоновая нить



варианты установки (см. стр. 19)

Высота установки в каждом отдельном случае должна выбираться в зависимости от высоты раковины.

Размеры (см. стр. 18)



Комплект (см. стр. 18)



Специальные принадлежности (см. стр. 18)

не включено в объем поставки!



Уплотнительная манжета #96383000

Удлинение 25 мм #96529000

Удлинение 25 мм #95413000





Знак технического контроля (см. стр. 36)



Монтаж см. стр. 17



Biztonsági utasítások

-  A szerelésnél a zúzódások és vágási sérülések elkerülése érdekében kesztyűt kell viselni.
-  A hidegvíz- és a melegvíz-csatlakozások közötti nagy nyomáskülönbséget kikell egyenlíteni!

Szerelési utasítások

- A szerelés előtt ellenőrizni kell, hogy a terméknek nincs-e szállítási sérülése. Beépítés után a szállítási-vagy felületi sérüléseket nem ismerik el.
- A csaptelepet az érvényben lévő előírásoknak megfelelően kell felszerelni, átöblíteni és ellenőrizni!
- A csaptelepet szigetelve és zajszigetelve kell felszerelni.

Szimbólumok leírása



Ne használjon ecetsavtartalmú szilikon!



Szükséges a fal megerősítése



Teflonszál



Szerelési példák (lásd a 19. oldalon)

A szerelési magasságot az egyes esetekben egyedileg kell beállítani a mosdóhoz képest.



Méretet (lásd a 18. oldalon)



Tartozékok (lásd a 18. oldalon)

Egyéb tartozék (lásd a 18. oldalon)

a szállítási egység nem tartalmazza
 Tömítőkarima #96383000
 Hosszabbítás 25 mm #96529000
 Hosszabbítás 25 mm #95413000





Vizsgajel (lásd a 36. oldalon)

Szerelés
lásd a 17. oldalon



Turvallisuusohjeet

-  Asennuksessa on käytettävä käsineitä puristumien ja viltojen aiheuttamien tapaturmien estämiseksi.
-  Suuret paine-erot kylmä- ja kuumavesiliitäntöjen välillä on tasattava.

Asennusohjeet

- Ennen asennusta on tarkastettava tuotteen mahdolliset kuljetusvahingot. Asennuksen jälkeen kuljetus- ja pintavaurioita ei hyväksytä.
- Kaluste on asennettava, huuhdeltava ja tarkastettava voimassa olevien määräysten mukaisesti!
- Hana on asennettava eristettynä ja äänenvaimennettuna.

Merkin kuvaus



Älä käytä etikahappopitoista silikonial!



Seinän vahvistus on tarpeen



Teflonnauha



Asennusesimerkkejä (katso sivu 19)

Asennuskorkeus on yksittäistapauksessa sovittava yksilöllisesti pesupöytäan sopivaksi.



Mitat (katso sivu 18)



Varaosat (katso sivu 18)

Eryityisvaruste (katso sivu 18)

ei kuulu toimitukseen



Tiivisterengas #96383000
 Pidennys 25 mm #96529000
 Pidennys 25 mm #95413000



Koestusmerkki (katso sivu 36)

Asennus
katso sivu 17



! Säkerhetsanvisningar

- △ Handskar ska bäras under monteringsarbetet så att man kan undvika kläm- och skärskadorgen werden.
- △ Stora tryckskillnader mellan anslutningarna för varmt och kallt vatten måste utjämnas.

Monteringsanvisningar

- Det måste undersökas om produkten har transportskador innan den monteras. Efter monteringen accepteras inga transport- eller ytskiktsskador.
- Blandaren måste installeras, genomspolas och testas enligt gällande föreskrifter.
- Blandaren måste monteras isolerat och ljudabsorberande.

Symbolförklaring



Använd inte silikon som innehåller ättiksyra!



Väggförstärkning nödvändig



Teflontråd



Monteringsexempel (se sidan 19)

Monteringshöjden måste anpassas till tvättstället i varje enskilt fall.



Måtten (se sidan 18)



Reservdelar (se sidan 18)

Specialtillbehör (se sidan 18)

medföljer ej leveransen



Tätningssmanschett #96383000
Förlängning 25 mm #96529000
Förlängning 25 mm #95413000



Testsigill (se sidan 36)

Montering
se sidan 17

! Saugumo technikos nurodymai

- △ Apsaugai nuo užspaudimo ir įsijovimo montavimo metu mūvėkite pirštines.
- △ Turi būti išlyginti šalto ir karšto slėgio nelygumai.

Montavimo instrukcija

- Prieš montuojant būtina patikrinti, ar gaminys nebuvo pažeistas transportavimo metu. Sumontavus pretenzijos dėl transportavimo ir paviršiaus pažeidimų nepriimamos.
- Maišytuvas privalo būti montuojamas, išleidžiamas ir patikrinamas pagal galiojančias normas!
- Maišytuvas turi būti sumontuotas izoliuotai ir naudojant garso izoliaciją.

Simbolio aprašymas



Nenaudokite silikono, kurio sudėtyje yra acto rūgšties!



Būtinās sienos sutvirtinimas



Teflono gija



Montavimo pavyzdžiai (žr. psl. 19)

Montavimo aukštis turi būti nustatomas individualiai pagal praustuvą.



Išmatavimai (žr. psl. 18)



Atsarginės dalys (žr. psl. 18)

Specialūs priedai (žr. psl. 18)

nėra pridedama



Sandarikliai #96383000
Ilgiklis 25 mm #96529000
Ilgiklis 25 mm #95413000



Bandyimo pažyma (žr. psl. 36)

Montavimas
žr. psl. 17





⚠ Sigurnosne upute

- ⚠ Prilikom montaže se radi sprječavanja prignječenja i posjekotina moraju nositi rukavice.
- ⚠ Velika razlika u pritisku između vruće i hladne vode mora biti izbalansirana.

Upute za montažu

- Prije montaže mora se provjeriti je li proizvod oštećen prilikom transporta. Nakon ugradnje se ne priznaju nikakve reklamacije koje se odnose na površinska i transportna oštećenja.
- Cijevi moraju biti postavljene, isprane i testirane prema važećim normama!
- Montirana armatura mora biti izolirana i zvučno odvojena.

Opis simbola



Nemojte koristiti silikon koji sadrži octenu kiselinu!



neophodno ojačanje zida



Teflonska nit



Primjeri instalacija (pogledaj stranicu 19)

Visina instalacije mora biti prilagođena visini umivaonika



Mjere (pogledaj stranicu 18)



Rezervni dijelovi (pogledaj stranicu 18)

Posebni pribor (pogledaj stranicu 18)



Nije sadržano u isporuci!
Manžeta za brtvljenje #96383000
Produljenje 25 mm #96529000
Produljenje 25 mm #95413000



Oznaka testiranja (pogledaj stranicu 36)

Sastavljanje
pogledaj stranicu 17



⚠ Güvenlik uyarıları

- ⚠ Montaj esnasında ezilme ve kesilme gibi yaralanmaları önlemek için eldiven kullanılmalıdır.
- ⚠ Sıcak ve soğuk su bağlantıları arasında büyük basınç farklılıkları varsa, bu basınç farklılıklarının dengelenmesi gerekir.

Montaj açıklamaları

- Montaj işleminden önce ürün nakliye hasarları yönünden kontrol edilmelidir. Montaj işleminden sonra nakliye veya yüzey hasarları için sorumluluk üstlenilmemektedir.
- Batarya geçerli normlara göre monte edilmeli, yıkanmalı ve kontrol edilmelidir!
- Armatür izoleli ve ses ayırmalı olarak monte edilmelidir.

Simge açıklaması



Asetik asit içeren silikon kullanmayın!



Duvar takviyesi gereklidir



Teflon ip



Montaj Örneği (Bakınız sayfa 19)

Montaj yüksekliği, münferit durumlarda evyeye özel olarak adapte edilmelidir.



Ölçüleri (Bakınız sayfa 18)



Yedek Parçalar (Bakınız sayfa 18)

Özel aksesuarlar (Bakınız sayfa 18)



Teslimat kapsamına dahil değildir
Sızdırmazlık manşeti #96383000
Uzatma 25 mm #96529000
Uzatma 25 mm #95413000





Kontrol işareti (Bakınız sayfa 36)

Montajı
Bakınız sayfa 17



Instrucțiuni de siguranță

-  La montare utilizați mănuși pentru evitarea contuziunilor și tăierii mâinilor.
-  Diferențele de presiune mari între alimentarea cu apă rece și apă caldă trebuie echilibrate.

Instrucțiuni de montare

- Înainte de instalare verificați, dacă produsul prezintă deteriorări de transport. După instalare garanția nu acoperă deteriorările de transport și cele de suprafață.
- Bateria trebuie montată, clătită și verificată conform normelor în vigoare.
- Armătura trebuie montată cu izolație termică și fonică.

Descrierea simbolurilor



Nu utilizați silicon cu conținut de acid acetic!



Este nevoie de consolidarea pereții.



Șnur teflon



Exemple de montare (vezi pag. 19)

Înălțimea de montare trebuie adaptată la cada de baie utilizată.



Dimensiuni (vezi pag. 18)



Piese de schimb (vezi pag. 18)

Accesorii opționale (vezi pag. 18)

nu este inclus în setul livrat





Manșetă de etanșare #96383000
 Prelungitor 25 mm #96529000
 Prelungitor 25 mm #95413000



Certificat de testare (vezi pag. 36)

Montare vezi pag. 17

Υποδειξεις ασφαλειας

-  Για να αποφύγετε τραυματισμούς κατά τη συναρμολόγηση πρέπει να φοράτε γάντια.
-  Οι διαφορές της πίεσης μεταξύ της σύνδεσης κρύου και ζεστού νερού θα πρέπει να αντισταθμίζονται.

Οδηγίες συναρμολόγησης

- Πριν τη συναρμολόγηση πρέπει να εξεταστεί το προϊόν για ζημιές μεταφοράς. Μετά την εγκατάσταση δεν αναγνωρίζονται ζημιές από τη μεταφορά ή επιφανειακές ζημιές.
- Η κεντρική βάνα πρέπει να τοποθετηθεί, να πλυθεί και να ελεγχθεί με βάση τους ισχύοντες κανόνες υδραυλικής τέχνης!
- Η μπαταρία πρέπει να τοποθετείται με κατάλληλη διάταξη ηχομόνωσης.

Περιγραφή συμβόλων



Μην χρησιμοποιείτε σιλικόνη που περιέχει οξικό οξύ!



Απαραίτητη ενίσχυση τοίχου



Νήμα Teflon



Παραδείγματα συναρμολόγησης (βλ. σελίδα 19)

Το ύψος της συναρμολόγησης θα πρέπει, σε κάθε μεμονωμένη περίπτωση, να προσαρμοστεί στο νιπτήρα.

Διαστάσεις (βλ. σελίδα 18)



Ανταλλακτικά (βλ. σελίδα 18)



Ειδικά αξεσουάρ (βλ. σελίδα 18)

δεν περιλαμβάνεται στον παραδοτέο εξοπλισμό
 Στεγανοποιητικό παρέμβυσμα #96383000
 Επιμήκυνση 25 mm #96529000
 Επιμήκυνση 25 mm #95413000





Σήμα ελέγχου (βλ. σελίδα 36)

Συναρμολόγηση βλ. σελίδα 17





Varnostna opozorila

-  Pri montaži je treba nositi rokavice, da se preprečijo poškodbe zaradi zmečkanja ali urezov.
-  Il est conseillé d'équilibrer les pressions de l'eau chaude et froide.

Navodila za montažo

- Pred montažo je treba izdelek preveriti glede morebitnih transportnih poškodb. Po vgradnji transportne ali površinske poškodbe ne bodo več priznane.
- Armaturo je potrebno montirati, sprati in testirati v skladu z veljavnimi normami!
- Armaturo morate montirati izolirano in zvočno neprepustno.

Opis simbola



Ne smete uporabiti silikona, ki vsebuje ocetno kislino!



Potrebno je ojačanje stene



Teflonsko vlakno



Primeri montaže (glejte stran 19)

Višino montaže je potrebno individualno prilagoditi umivalniku.



Mere (glejte stran 18)



Rezervni deli (glejte stran 18)

Poseben pribor (glejte stran 18)

Ni vključeno



Tesnilna manšeta #96383000

Podaljšek 25 mm #96529000

Podaljšek 25 mm #95413000





Preskusni znak (glejte stran 36)

Montaža
Glejte stran 17.



Ohutusjuhised

-  Kandke paigaldamisel muljumis- ja löikevigastuste vältimiseks kindaid.
-  Kui külma ja kuuma vee ühenduste surve on väga erinev, tuleb need tasakaalustada.

Paigaldamisjuhised

- Enne paigaldamist tuleb toodet kontrollida transportikahjustuste osas. Pärast paigaldamist ei tunnustata enam transporti- või pinnakahjustuste kaebuseid.
- Segisti paigaldamine, loputamine ja kontroll peab toimuma vastavalt kehtivatele normidele!
- Armatuur tuleb paigaldada isoleeritult ja helikindlalt.

Sümbolite kirjeldus



Ärge kasutage aädikhapet sisaldavat silikooni!



Vajalik seinatugevdus



teflonkiud



Paigalduse näited (vt lk 19)

Paigaldamiskõrgus tuleb individualsest kohandada valamü järgi.



Mõõtude (vt lk 18)



Varuosad (vt lk 18)

Spetsiaalne lisavarustus (vt lk 18)

ei sisaldu komplektis
tihendi #96383000

pikendus 25 mm #96529000

pikendus 25 mm #95413000



Kontrollsertifikaat (vt lk 36)

Paigaldamine
vt lk 17



Drošības norādes

- ⚠ Montāžas laikā, lai izvairītos no spiedumiem un iegriezumiem, nepieciešams nēsāt cimdus.
- ⚠ Jāizlīdzina spiediena atšķirības starp aukstā un karstā ūdens pievadiem.

Norādījumi montāžai

- Pirms montāžas nepieciešams pārbaudīt, vai produktam transportēšanas laikā nav radušies bojājumi. Pēc iebūvēšanas bojājumi, kas radušies transportēšanas laikā, vai virsmas bojājumi netiek atzīti.
- Armatūra jāuzstāda, jāizskalo un jāpārbauda atbilstoši spēkā esošajām normām!
- Armatūra montējama izolēti un ar skaņas izolāciju.

Simbolu nozīme



Neizmantot silikonu, kas satur etiķskābi!



Nepieciešama sienas stiprināšana



Teflona diegi



Montāžas piemēri (skat. 19. lpp.)

Montāžas augstums atsevišķos gadījumos individuāli jāpiemēro izlietnei.



Izmērus (skat. 18. lpp.)



Rezerves daļas (skat. 18. lpp.)

Speciāli aksesuāri (skat. 18. lpp.)

komplektā netiek piegādāts



Blīvējuma uzmava #96383000
 Pagarinājums 25 mm #96529000
 Pagarinājums 25 mm #95413000



Pārbaudes zīme (skat. 36. lpp.)

Montāža
skat. 17. lpp.



Sigurnosne napomene

- ⚠ Prilikom montāžē se radi sprečavanja prignječenja i posekotina moraju nositi rukavice.
- ⚠ Velika razlika u pritisku između vruće i hladne vode mora biti izbalansirana.

Instrukcije za montažu

- Pre montažu se mora proveriti da li je proizvod oštećen pri transportu. Nakon ugradnje se ne priznaju nikakve reklamacije koje se odnose na površinska i transportna oštećenja.
- Armatūra mora biti postavljena, isprana i testirana prema važećim normama!
- Armatūra se mora montirati tako da bude izolovana i zvučno odvojena.

Opis simbola



Nemojte koristiti silikon koji sadrži sirćetnu kiselinu!



neophodno ojačanje zida



Teflonska nit



Primeri montaže (vidi stranu 19)

Visina instalacije mora biti prilagođena visini umivaonika.



Mere (vidi stranu 18)



Rezervni delovi (vidi stranu 18)

Poseban pribor (vidi stranu 18)

Nije sadržano u isporuci



Zaptivna manžeta #96383000
 Produžetak 25 mm #96529000
 Produžetak 25 mm #95413000





Ispitni znak (vidi stranu 36)

Montaža
vidi stranu 17



Sikkerheshenvisninger

-  Bruk hansker under montasjen for å unngå klem- og kuttskader.
-  Store trykkdifferanser mellom kaldt- og varmtvannstilkoblinger skal utlignes.

Montagehenvisninger

- Før montasjen skal produktet sjekkes for transportskader. Etter monteringen aksepteres ikke noen transport- eller overflateskader.
- Armaturen skal monteres iht. gyldige standarder. De skal spyles og sjekkes!
- Armaturen skal monteres isolert og støyfrikloblet.

Symbolbeskrivelse



Ikke bruk silikon som inneholder eddiksyre!



Veggforsterkning er nødvendig



Teflonfibre



Montasje-eksempel (se side 19)

I enkelte tilfeller skal montasjehøyden tilpasses vaskeservanten.



Mål (se side 18)



Serviceleder (se side 18)

Ekstratilbehør (se side 18)

ikke med i leveransen





Tetningsmansjett #96383000
 Forlengelse 25 mm #96529000
 Forlengelse 25 mm #95413000



Prøvemerket (se side 36)

Montasje se side 17

Указания за безопасност

-  При монтажа трябва да се носят ръкавици, за да се избегнат наранявания поради притискане или порязване.
-  Големите разлики в налягането между изводите за студената и топлата вода трябва да се изравняват.

Указания за монтаж

- Преди монтажа продуктът трябва да се провери за транспортни щети. След монтажа не се признават транспортни или повърхностни щети.
- Арматурата трябва да се монтира, промие и провери в съответствие с валидните норми!
- Арматурата трябва да се монтира изолирана и не свързана с шум.

Описание на символите



Не използвайте силикон, съдържащ оцетна киселина!



Необходимо е усиление на стената



Тefлонов конец



Примери за монтаж (вижте стр. 19)

Монтажната височина при отделните случаи трябва индивидуално да се пригоди към умивалника.

Размери (вижте стр. 18)



Сервизни части (вижте стр. 18)

Специални принадлежности (вижте стр. 18)

не се съдържа в обема на доставка
 Уплътнителен маншет #96383000
 Удължител 25 мм #96529000
 Удължител 25 мм #95413000



Контролен знак (вижте стр. 36)



Монтаж вижте стр. 17



⚠ Udhëzime sigurie

- ⚠ Për të evituar lëndimet e pickimeve ose të prerjeve gjatë procesit të montimit duhet që të vishni doreza.
- ⚠ Ndryshimet e mëdha të presionit mes lidhjeve të ujit të ftohtë dhe atij të ngrohtë duhen ekuilibruar.

Udhëzime për montimin

- Përpara montimit duhet që produkti të kontrollohet për dëmtime nga transporti. Pas instalimit nuk do të njihet asnjë dëmtim nga transporti ose dëmtim i sipërfaqes.
- Armatura duhet montuar, shpërlarë dhe kontrolluar në bazë të normave të vlefshme!
- Valvula duhet të izolohet dhe të izoluar akustikisht montuar.

Përshkrimi i simbolit



Mos përdorni silikon që në përbërje ka acid acetik.



Nevojitet përforcimi i murit



Fije Tefloni



Shembuj të montimit (shih faqen 19)

Lartësia e montimit në raste të veçanta i duhet përshtatur në mënyrë individuale lavamanit.



Përmasat (shih faqen 18)



Pjesë ndërrimi (shih faqen 18)

Pajisje të posaçme (shih faqen 18)

nuk përfshihet në vëllimin e furnizimit
Mansheta izoluese #96383000

Zgjatësi 25 mm #96529000

Zgjatësi 25 mm #95413000



Shenja e kontrollit (shih faqen 36)

Montimi shih faqen 17



⚠ تنبيهات الأمان

- ⚠ يجب ارتداء قفازات لليد أثناء التركيب لتجنب حدوث أضرار الإنحسار أو الجروح.
- ⚠ يجب أن يكون تيار الماء الساخن والماء البارد متعادلين في الضغط.

تعليمات التركيب

- قبل القيام بعملية التركيب، يجب فحص المنتج للتأكد من خلوه من أية تلفيات ناتجة عن النقل. بعد القيام بعملية التركيب، لن يتم الاعتراف بوجود أية تلفيات سطحية أو تلفيات ناتجة عن عملية النقل.
- يجب تركيب الوصلة، وغمرها بالماء واختبارها وفقاً للمعايير السارية!
- يجب تركيب خلاط المياه بعد عزله وفصله عن الاحتكاكات بمواد البناء داخل المكان الذي يركب به.

وصف الرمز



هام! لا تستخدم السليكون الذي يحتوي على أمضاض!



المنطقة الخاصة بالتدعيم المطلوب للجدار



خيوط تفلون



مثال على التركيب (راجع صفحة 19)

يجب ضبط ارتفاع التركيب بالنسبة للحوض بشكل مناسب للمستخدم.

أبعاد (راجع صفحة 18)

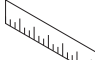

قطع الغيار (راجع صفحة 18)



ملحقات خاصة (راجع صفحة 18)
غير مدرج مع المحتويات المسلمة

رقاقة إغلاق #96383000

وصلة إطالة 25 مم #96529000

وصلة إطالة 25 مم #95413000



شهادة اختبار (راجع صفحة 36)



التركيب راجع صفحة 17

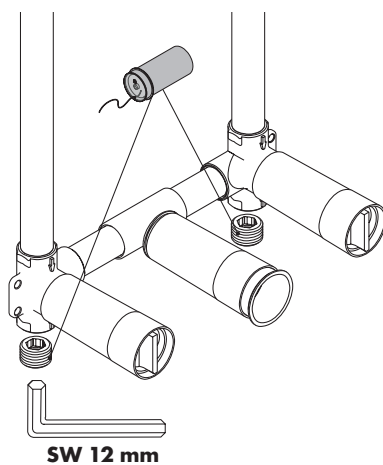
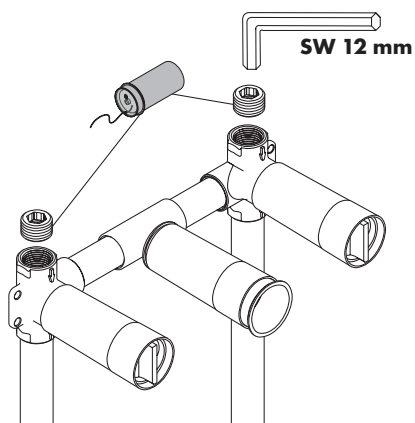
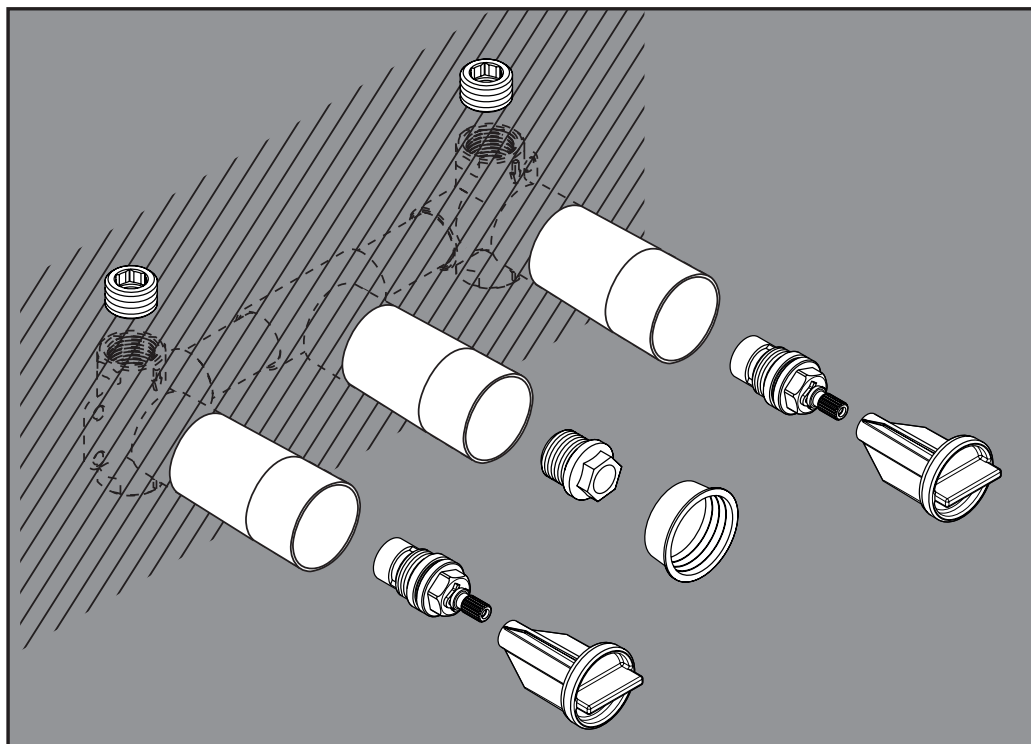

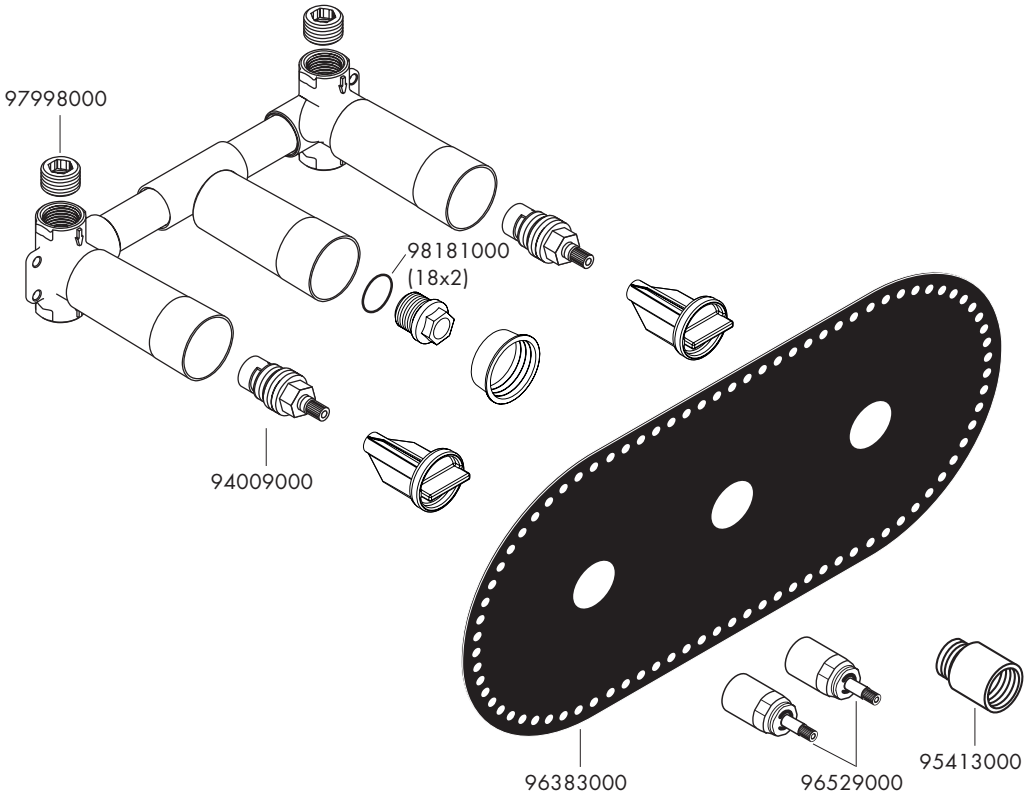
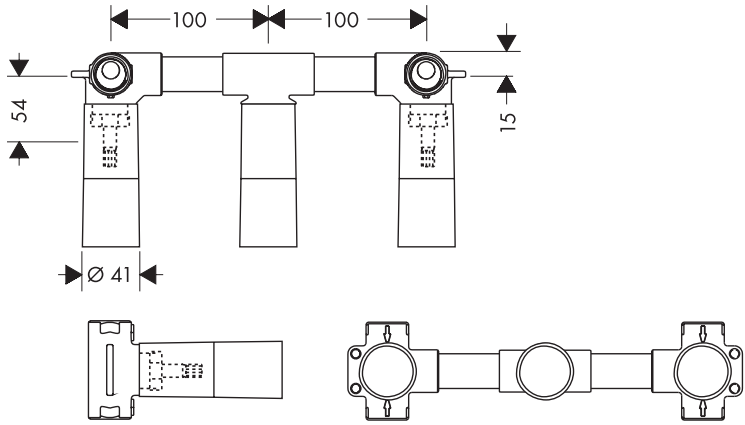



Starck 10313XXX

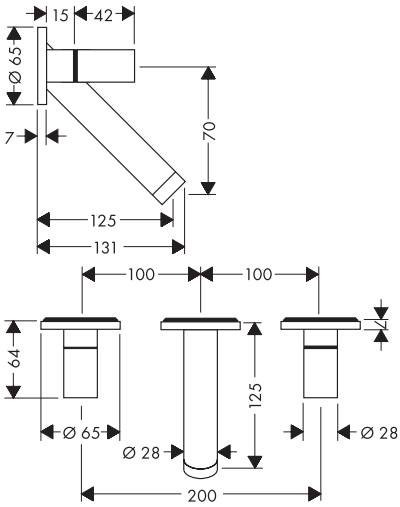
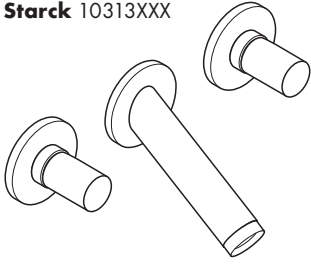

Montreux 16532XXX

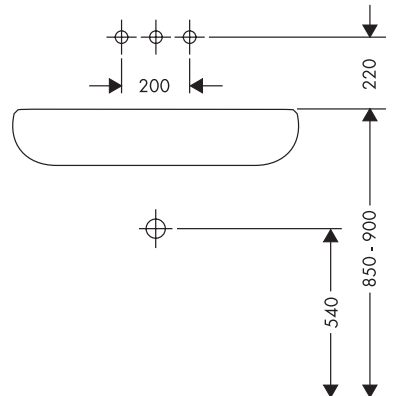
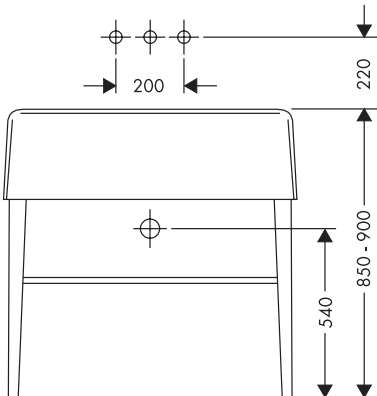
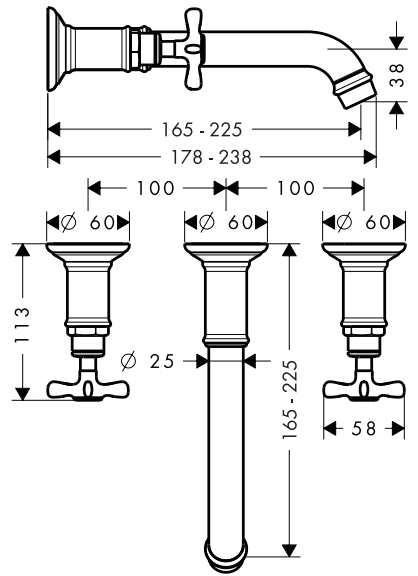
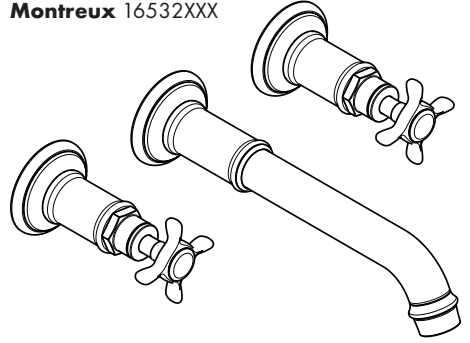



Urquiola 11042XXX

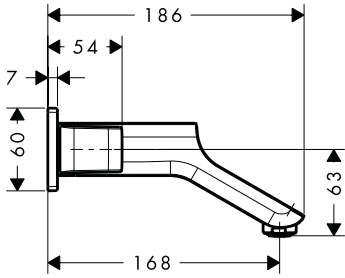
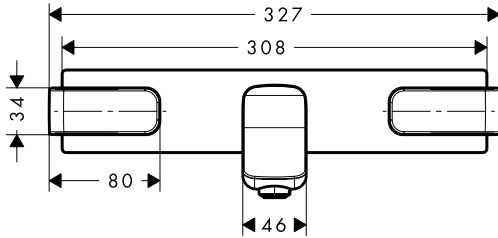
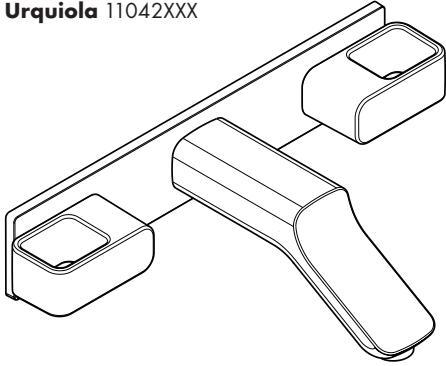

Urquiola 11043XXX

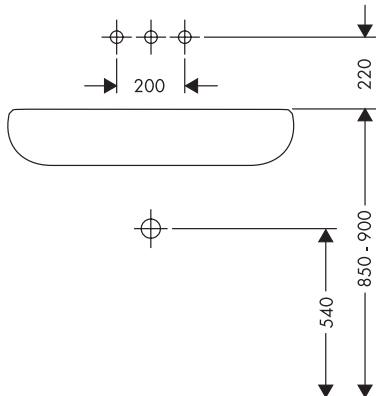
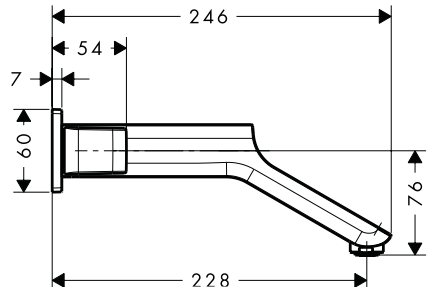
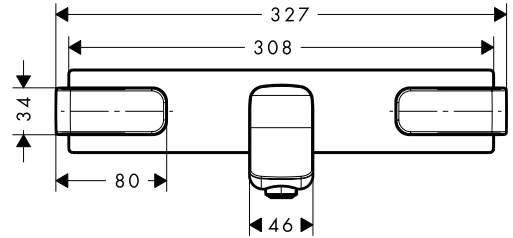
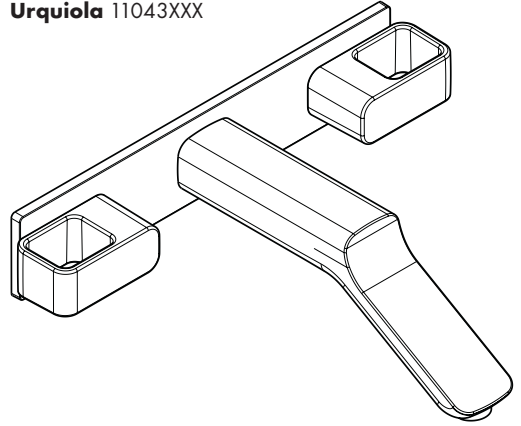

Citterio M 34215XXX

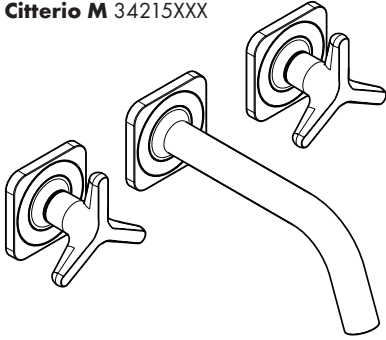

Citterio M 34217XXX

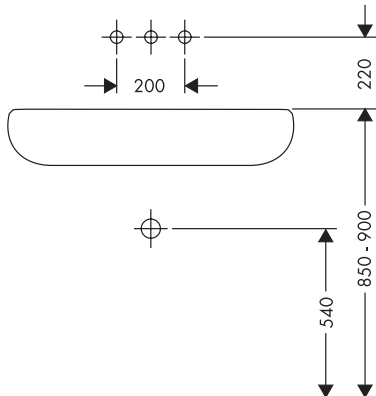
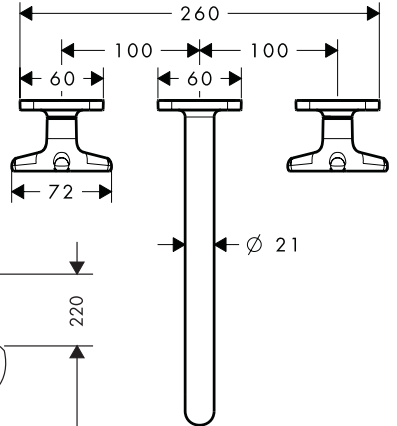
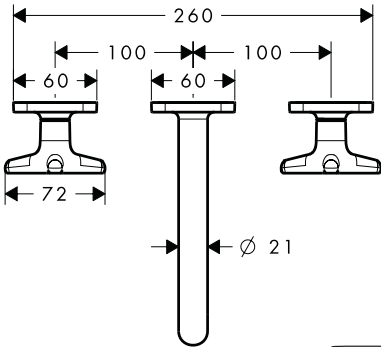
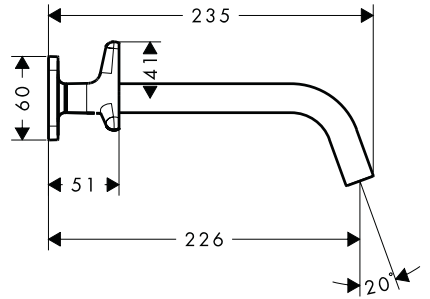
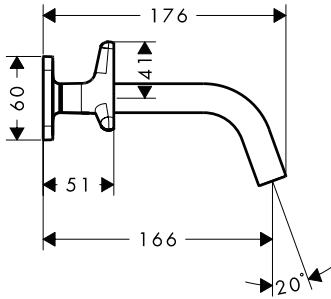
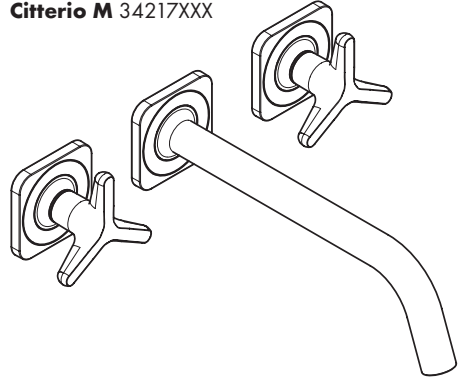



Citterio M 34313XXX

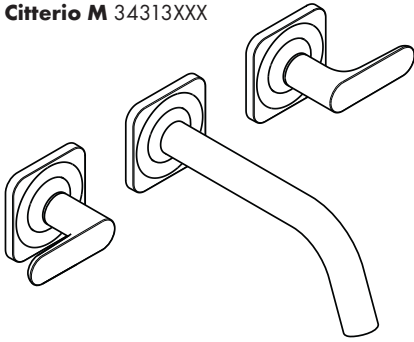

Citterio M 34315XXX

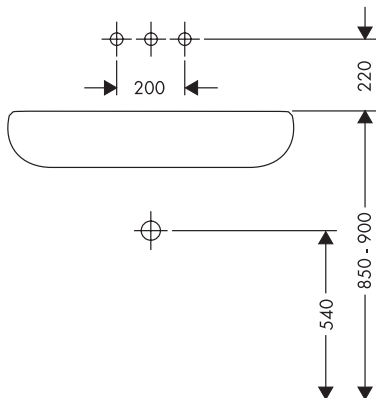
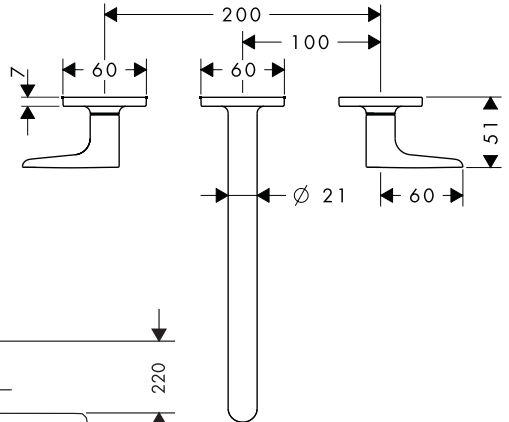
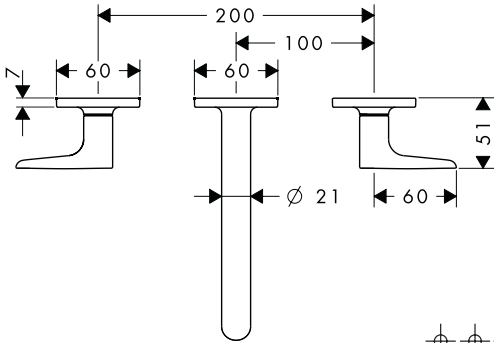
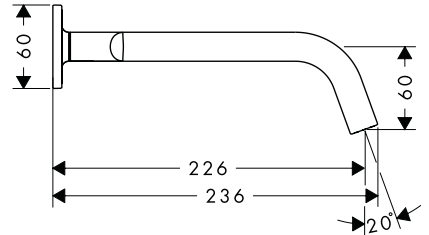
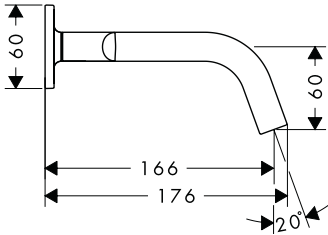
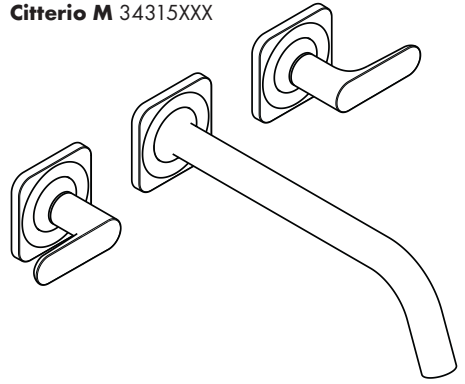

Citterio M 34314XXX

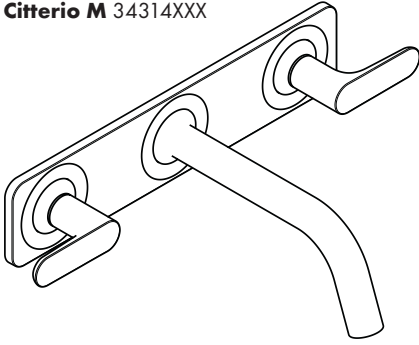

Citterio M 34316XXX

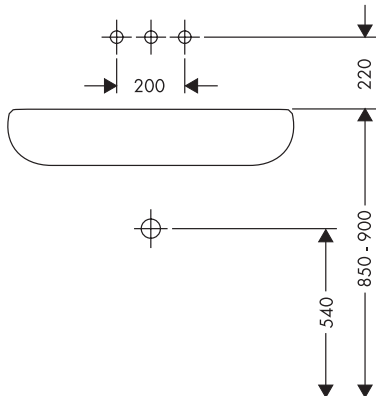
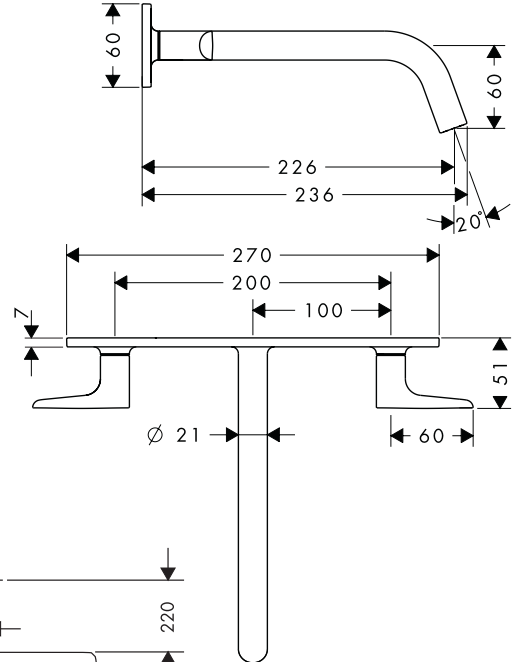
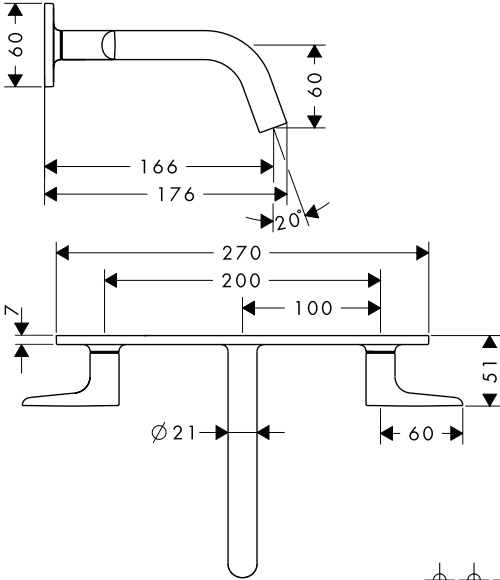
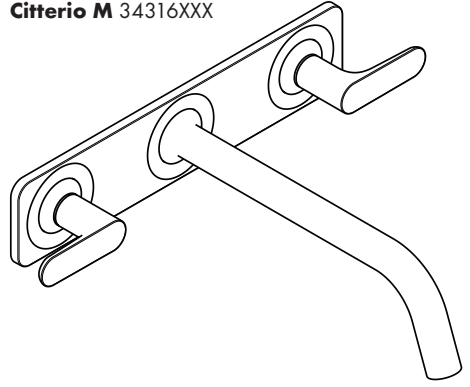



Citterio 39314XXX

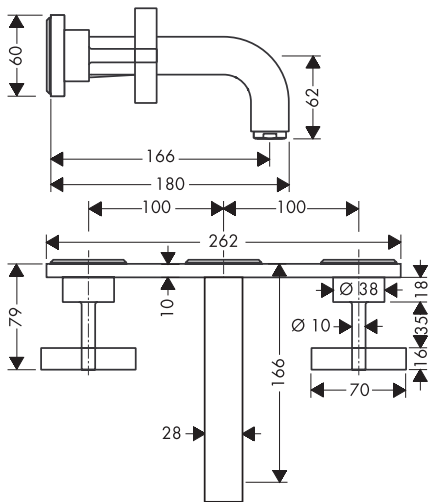
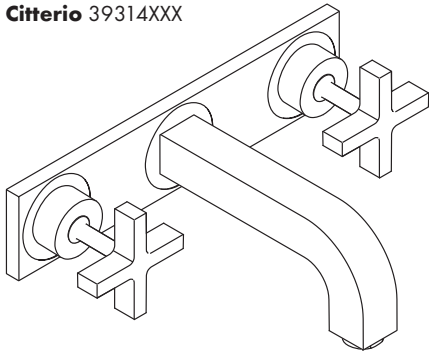

Citterio 39144XXX

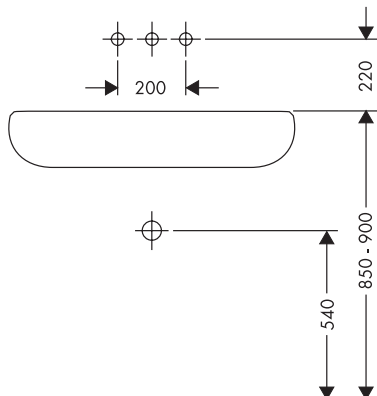
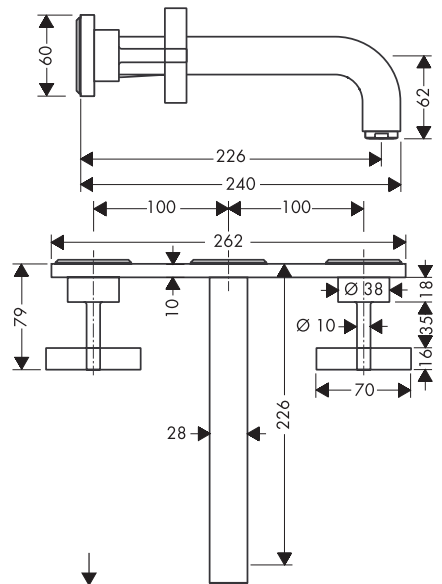
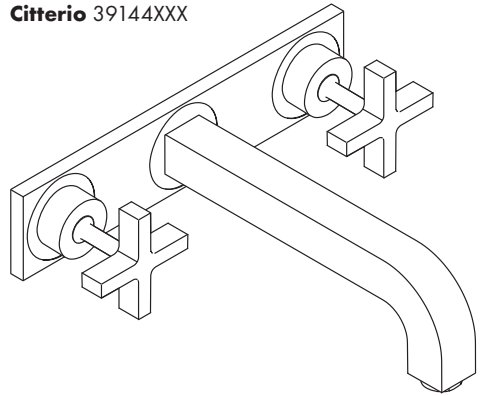

Citterio 39313XXX

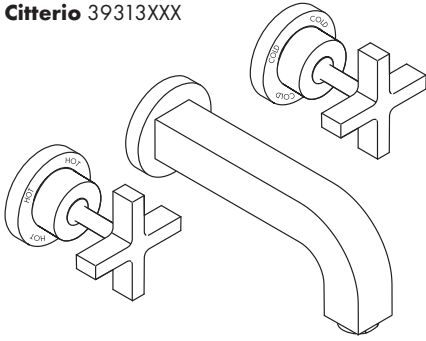

Citterio 39143XXX

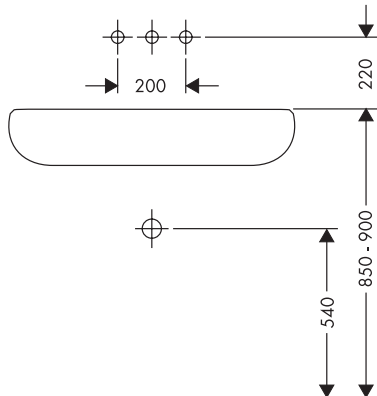
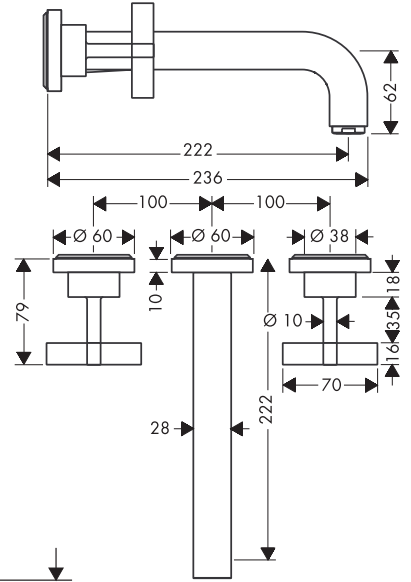
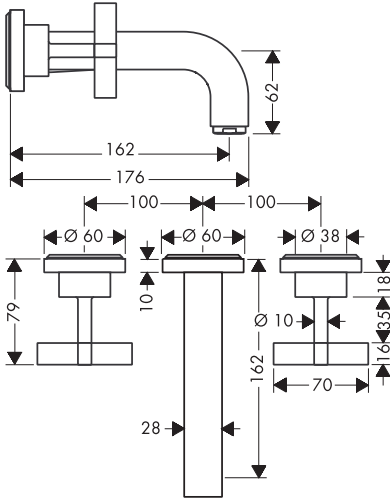
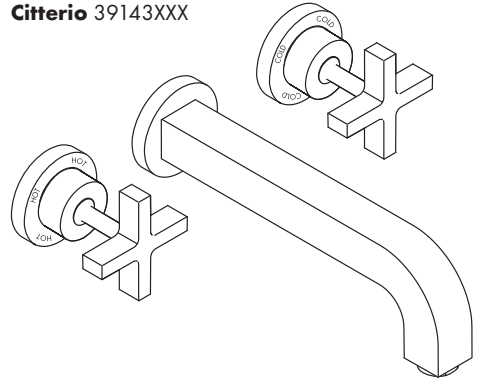



Citterio 39316XXX

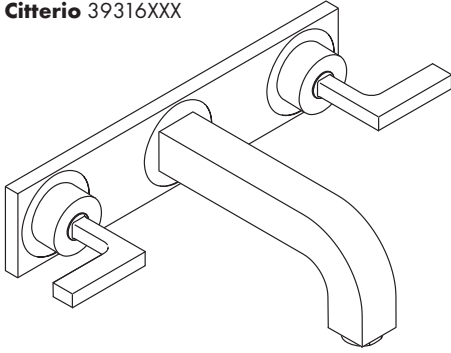

Citterio 39148XXX

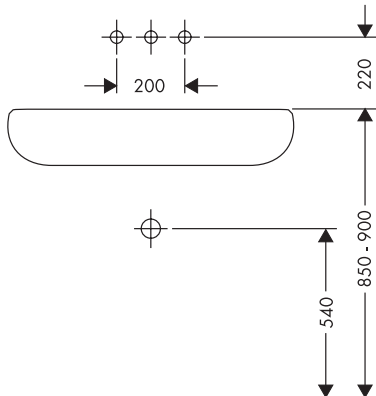
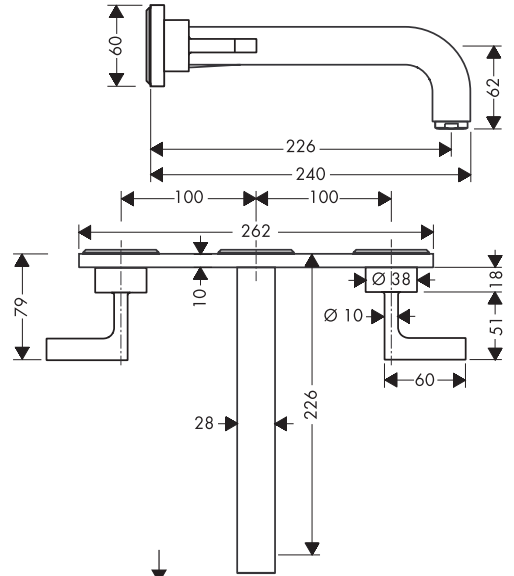
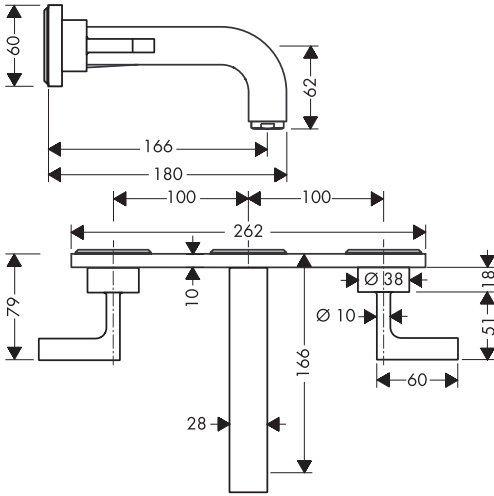
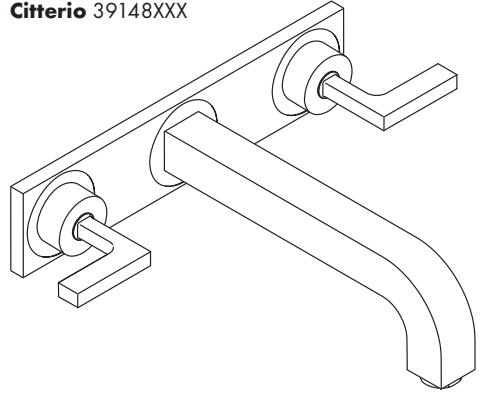

Citterio 39315XXX

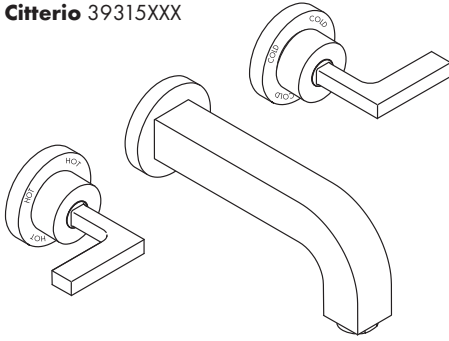

Citterio 39147XXX

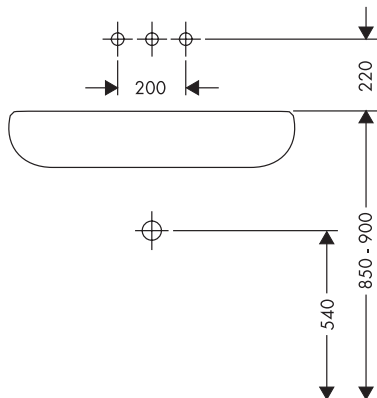
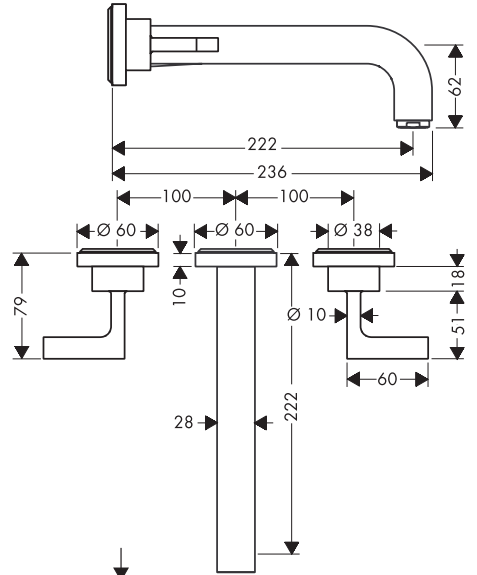
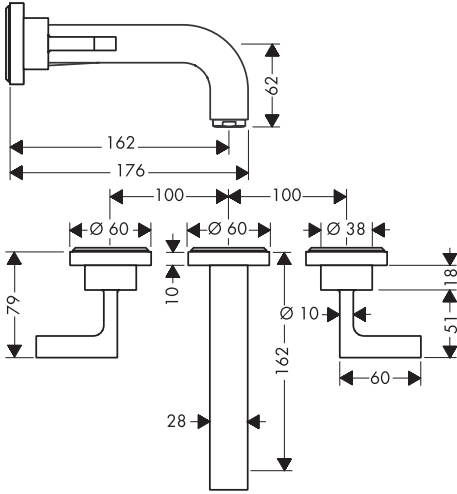
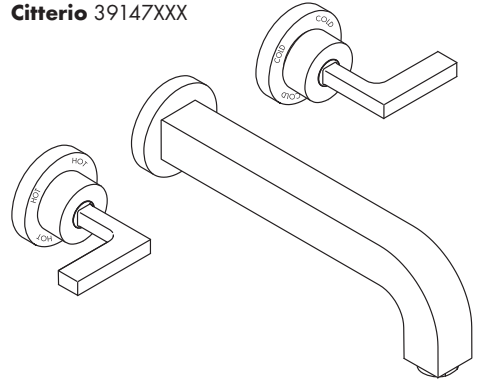



Citterio 39441XXX

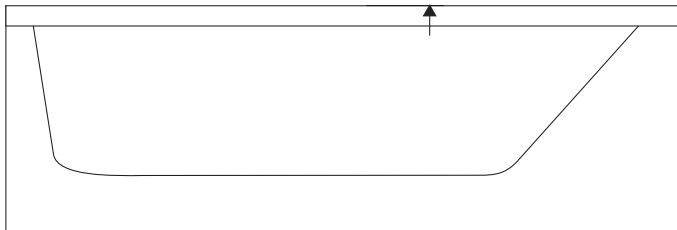
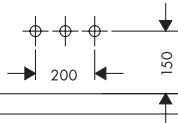
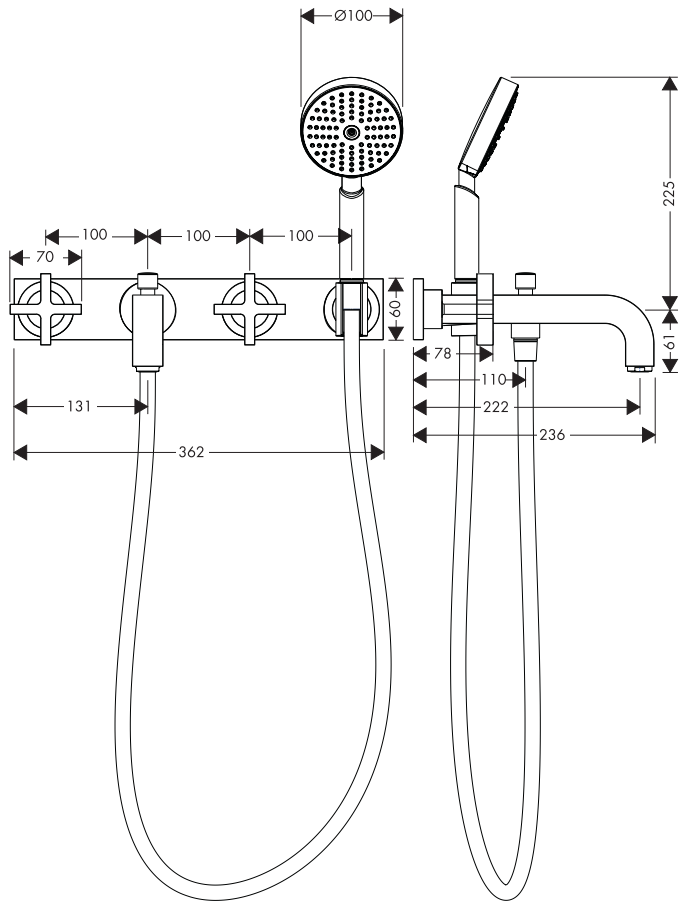
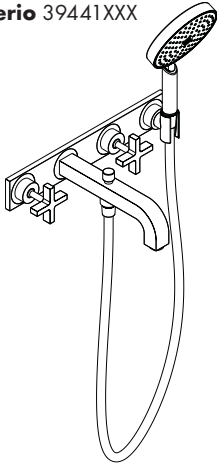

Citterio 39442XXX

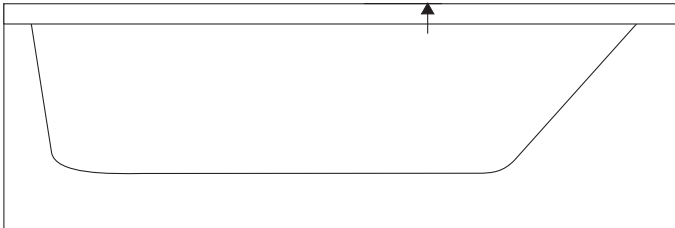
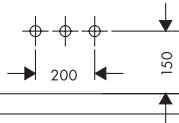
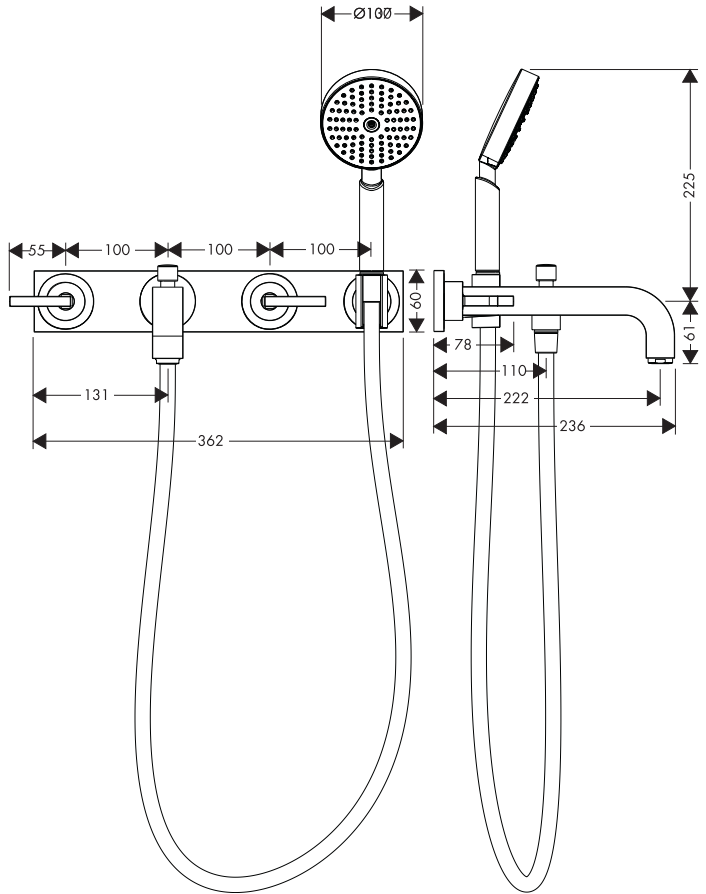
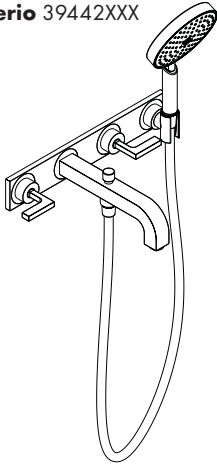



Citterio 39447XXX

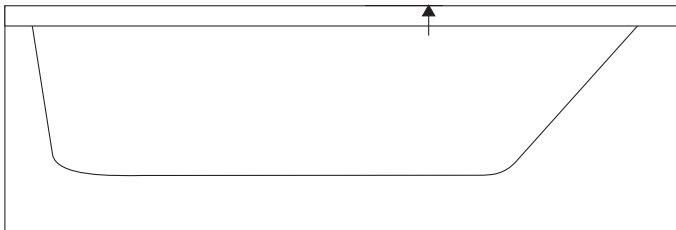
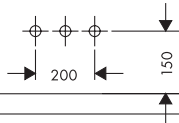
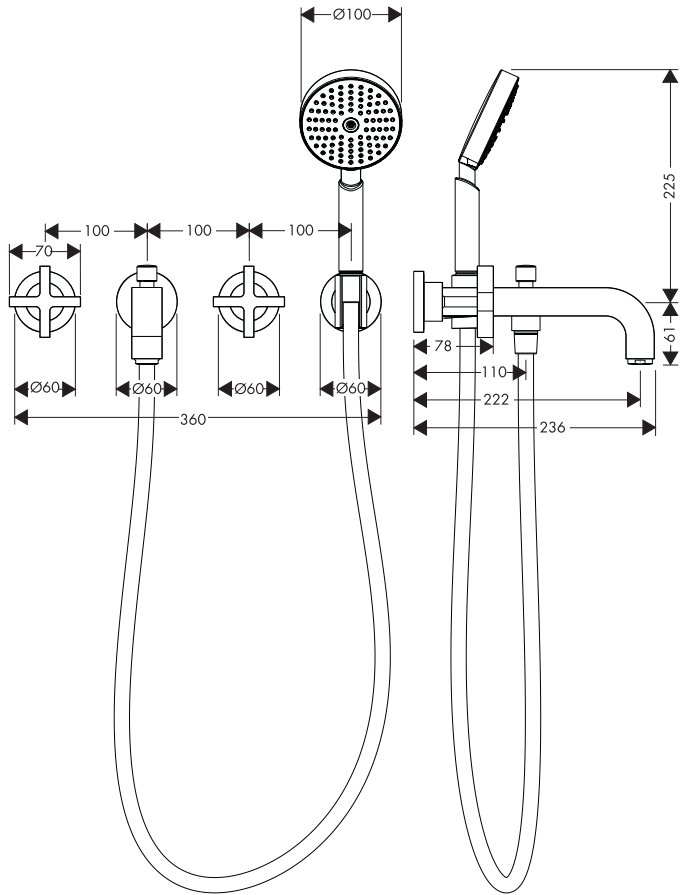
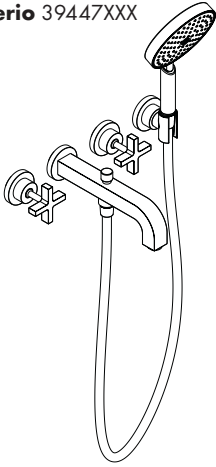



Bouroullec 19135XXX

Bouroullec 19136XXX

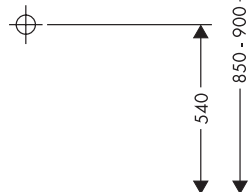
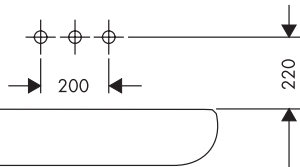
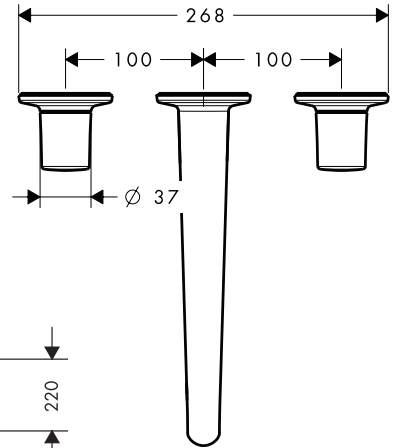
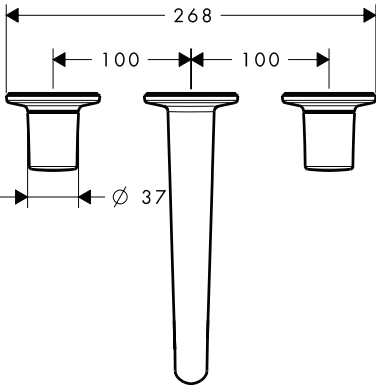
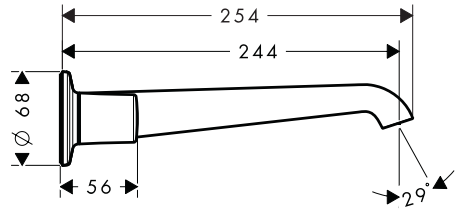
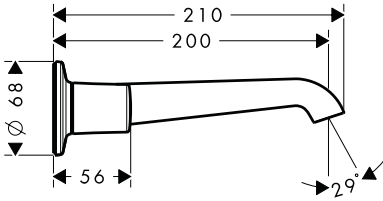
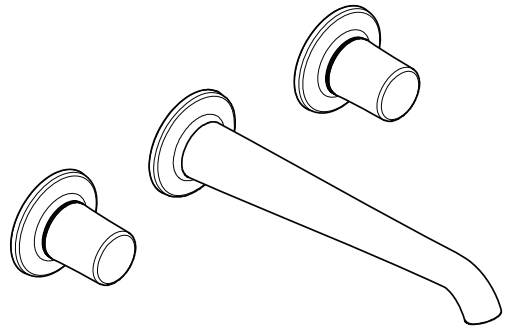
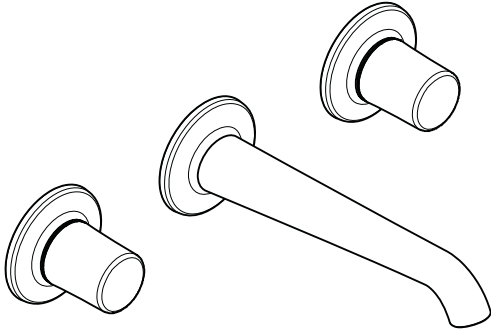

Bouroullec 19158XXX

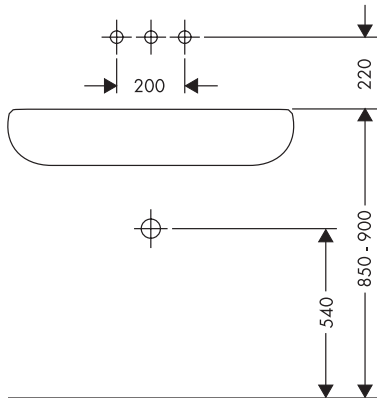
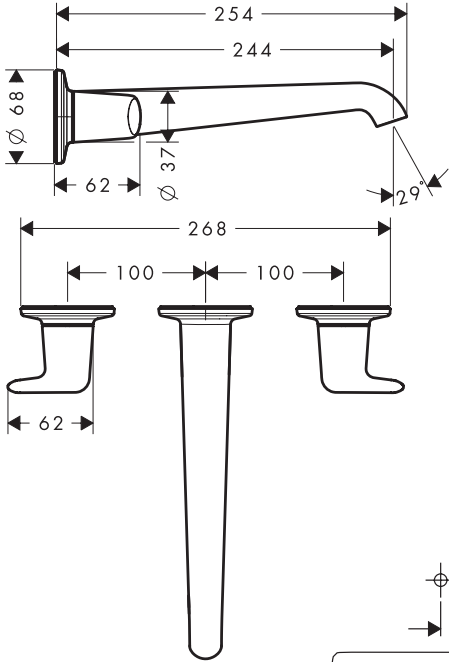
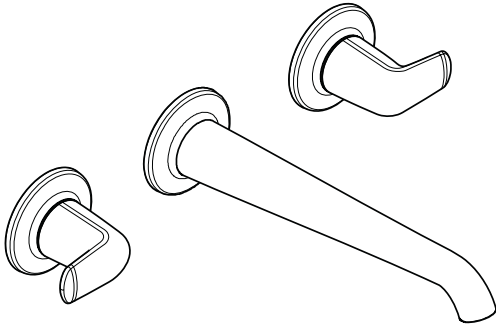





	P-IX	DVGW	SVGW	ACS	WRAS	ETA
10303180	P-IX 19149/IA	BT0602	X	X	X	 1.42/19070



hansgrohe