

KineStyle

AQUALIGHT

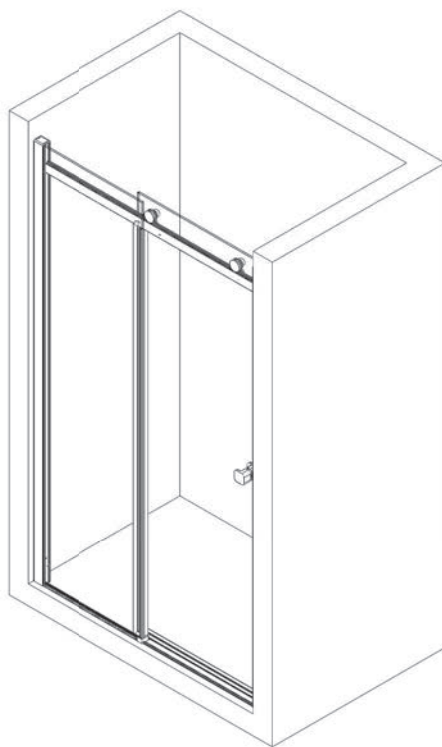

Instructions de montage - FR
Nettoyage et entretien -

Istruzioni di montaggio - IT
Pulizia e manutenzione -

Montageinstructies - NL
Reiniging en onderhoud -

Instrucciones de montaje - ES
Limpeza y mantenimiento -

DES1046D

**Avant l'installation
Prima dell'installazione
Voor de installatie
Antes de la instalación**

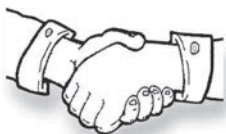

**Nous vous remercions d'avoir choisi
notre produit**

**Vi ringraziamo per aver scelto
un nostro prodotto**

**Wij danken u dat u voor ons product
heeft gekozen**

**Le agradecemos que haya elegido
un producto nuestro**

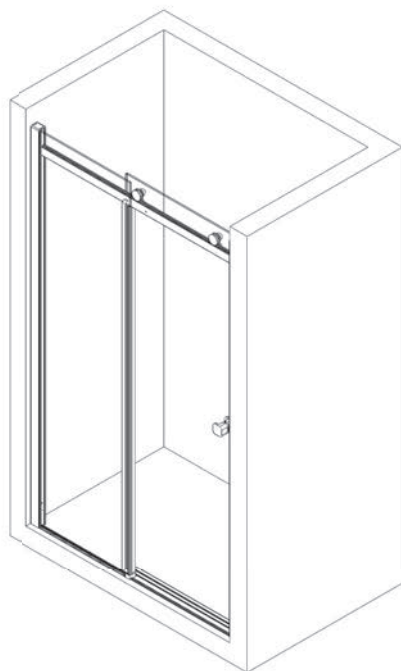

FR **IMPORTANT**
Avant de commencer l'installation,
lire ce livret d'instructions.

IT **IMPORTANTE**
Prima di iniziare l'installazione
leggere il presente libretto istruzioni.

NL **BELANGRIJK**
Lees dit instructieboekje voordat
u met de installatie begint.

ES **IMPORTANTE**
Antes de empezar con la instalación
lea el manual de instrucciones.

Avant l'installation Prima dell'installazione Voor de installatie Antes de la instalación

- FR** - Une fois les composants retirés des emballages, vérifier visuellement qu'ils soient sans défaut.
- Signaler tout défaut au fournisseur avant l'assemblage des différentes parties de l'installation.
 - Il ne sera possible d'accepter les réclamations relatives à des imperfections du produit qu'A CONDITION que celles-ci soient signalées avant l'assemblage des différentes parties et avant l'installation.

-
- IT** - Dopo aver rimosso i componenti dagli imballi, verificare visivamente che gli stessi non presentino difetti.
- Qualsiasi difetto deve essere segnalato al fornitore prima dell'assemblaggio delle varie parti e dell'installazione.
 - Qualsiasi reclamo relativo a imperfezioni del prodotto sarà accettato SOLO se segnalato prima dell'assemblaggio delle varie parti e dell'installazione.

-
- NL** - Controleer visueel na de onderdelen uit de verpakking te hebben gehaald of de componenten defecten vertonen.
- Elk defect moet worden gemeld aan de leverancier vóór montage van de verschillende onderdelen en installatie.
 - Eventuele klachten over onvolmaaktheden van het product worden UITSLUITEND geaccepteerd indien gemeld vóór de montage van de verschillende onderdelen en installatie.

-
- ES** - Después de haber quitado los embalajes, comprobar visualmente que los componentes no presenten defectos.
- Cualquier defecto debe ser indicado al proveedor antes del ensamblaje de las diferentes partes y de la instalación, en un plazo de 24 horas.
 - Cualquier reclamación relativa a imperfecciones del producto será aceptada SOLAMENTE si se indica antes del ensamblaje de las diferentes partes y de la instalación, dentro del plazo indicado.

Table des matières Indice Inhoudstafel Índice

FR	- Composants fournis	Pag. 5
	- Sequence de montage	Pag. 13
	- Informations sur l'utilisation	Pag. 42
	- Nettoyage et entretien	Pag. 44
IT	- Componenti fornitura	Pag. 5
	- Sequenza di montaggio	Pag. 13
	- Informazioni sull'utilizzo	Pag. 42
	- Pulizia e manutenzione	Pag. 44
NL	- Geleverde onderdelen	Pag. 5
	- Montagevolgorde	Pag. 13
	- Informatie over het gebruik	Pag. 42
	- Reiniging en onderhoud	Pag. 44
ES	- Componentes entregados	Pag. 5
	- Secuencia de montaje	Pag. 13
	- Informaciones sobre el uso	Pag. 42
	- Limpieza y mantenimiento	Pag. 44



**Exécuter l'installation et l'assemblage
de la cabine en respectant la séquence illustrée**

**Eseguire l'installazione e l'assemblaggio della cabina
chiusura rispettando la sequenza illustrata.**



**Voer de installatie en montage van de douchecabine
in de aangegeven volgorde uit**

**Realizar la instalación y el ensamblaje de la cabina
respetando la secuencia ilustrada**

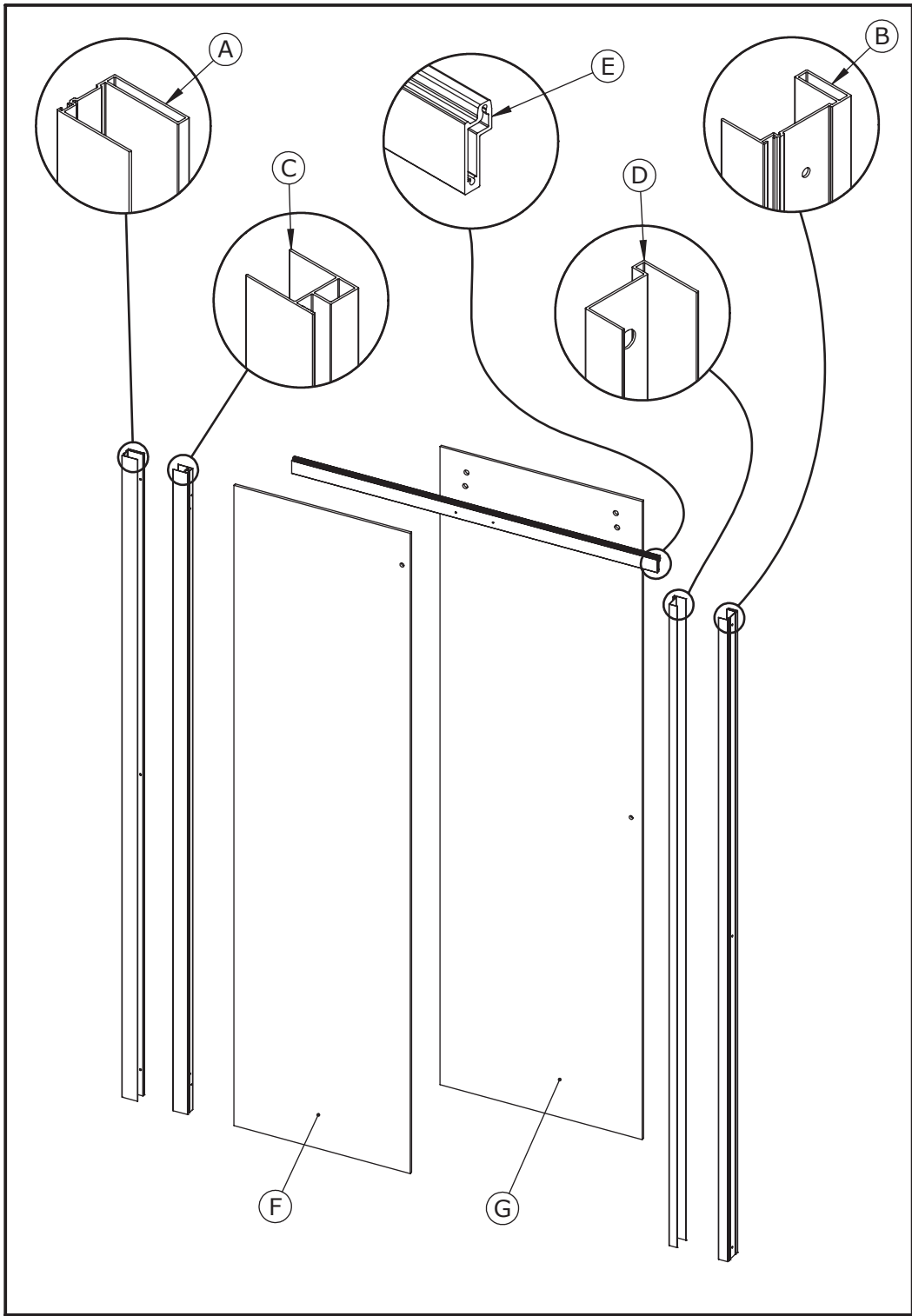



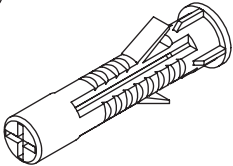
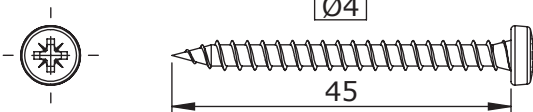

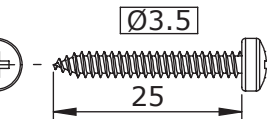
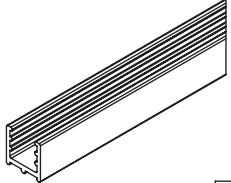
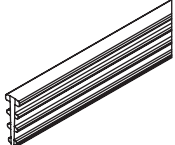
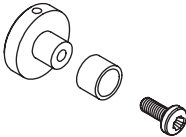
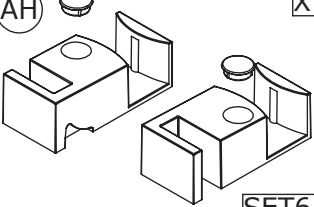
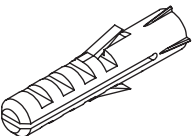
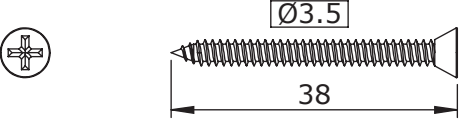
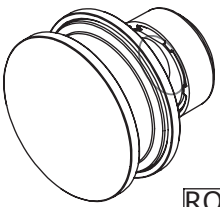
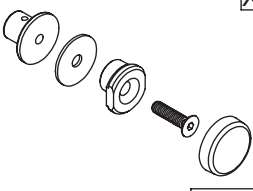
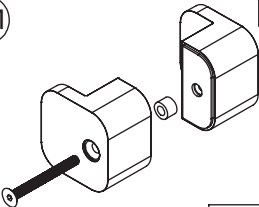
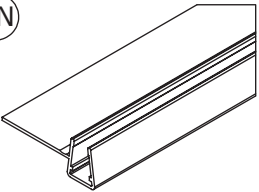
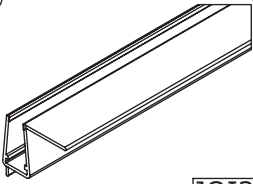
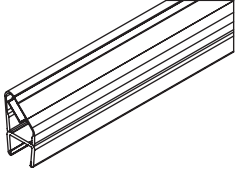

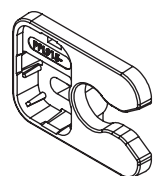
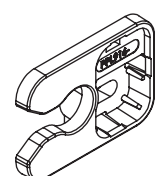

DES1046D

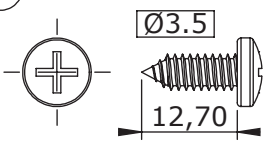
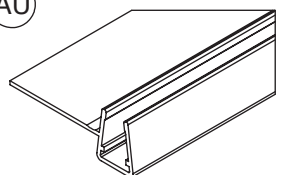
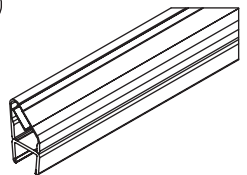
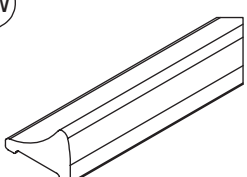
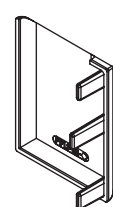
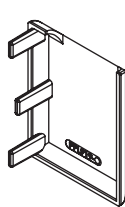
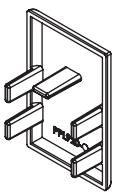
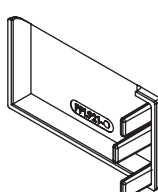
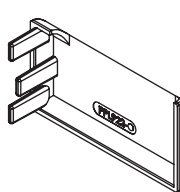
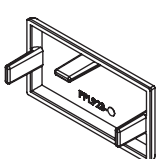
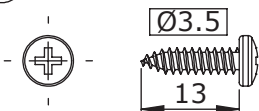
<p>(AA) X6</p>  <p>CHE02</p>	<p>(AC) X6</p>  <p>Ø4 45</p> <p>1=1</p> <p>VIS210</p>	
<p>(AB) X6</p>  <p>RON05</p>	<p>(AD) X4</p>  <p>Ø3.5 25</p> <p>1=1</p> <p>VIS3.5x25</p>	<p>(AE) X1</p>  <p>6142</p>
<p>(AF) X1</p>  <p>Lg=1984mm</p> <p>J637</p>	<p>(AG) X1</p>  <p>SET67</p>	<p>(AH) X1</p>  <p>SET65</p>
<p>(AI) X1</p>  <p>CHE03</p>	<p>(AJ) X1</p>  <p>Ø3.5 38</p> <p>1=1</p> <p>VIS42</p>	
<p>(AK) X2</p>  <p>ROU40</p>	<p>(AL) X2</p>  <p>SET66</p>	<p>(AM) X1</p>  <p>SET70</p>
<p>(AN) X1</p>  <p>Lg=1863mm</p> <p>J636</p>	<p>(AO) X1</p>  <p>JOI258</p>	<p>(AP) X1</p>  <p>Lg=1970mm</p> <p>AI119</p>

Les quantités données sont les quantités utiles au montage. Les sachets fournis contiennent des pièces supplémentaires.
The quantities given are what are required for the installation. There may be some surplus in the package provide.

<p>AQ X1</p>  <p>PPL915</p>	<p>X1</p>  <p>PPL916</p>	<p>AS X1</p>  <p>PPL917</p>
<p>AT X1</p>  <p>1 = 1 VIS132</p>	<p>AU X1</p>  <p>Lg=1854mm J635</p>	<p>AV X1</p>  <p>Lg=1999mm AI121</p>
<p>AW X1</p>  <p>5905</p>	<p>AX X1</p>  <p>PPL918</p>	<p>X1</p>  <p>PPL919</p>
<p>AY X1</p>  <p>PPL920</p>	<p>AZ X1</p>  <p>PPL921</p>	<p>X1</p>  <p>PPL922</p>
<p>BA X1</p>  <p>PPL923</p>	<p>BB X6</p>  <p>1 = 1 VIS117</p>	<p>BC X12</p>  <p>CAP19</p>
<p>BD X7</p>  <p>CAP20</p>	<p>BE X1</p>  <p>RON02</p>	<p>BF X1</p>  <p>RON34</p>

Les quantités données sont les quantités utiles au montage. Les sachets fournis contiennent des pièces supplémentaires.

The quantities given are what are required for the installation. There may be some surplus in the package provide.

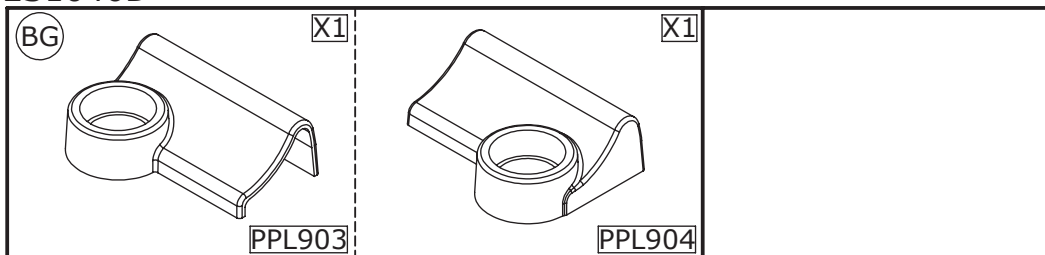

MATERIEL NEESSAIRE - TOOLS REQUIRED - MATERIALE NECESSARIO
MATERIAL NECESARIO - NODIGE GEREEDSCHAP

Colle polyuréthane
Polyurethane glue
Colla poliuretano
Pegamento poliuretano
Lijm polyurethaan

Non acétique
No acetic
Non acetico
No acética
Zonder azijnzuur

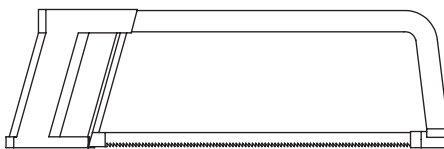
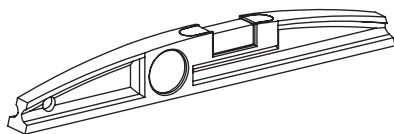
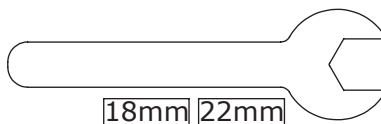
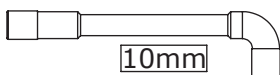
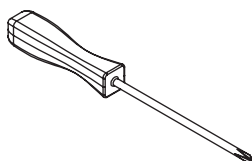
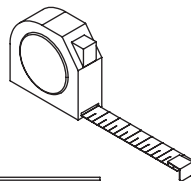
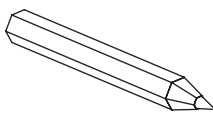
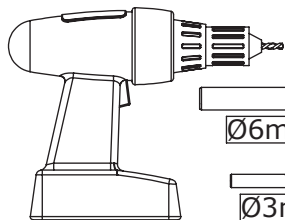
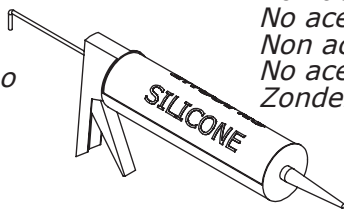
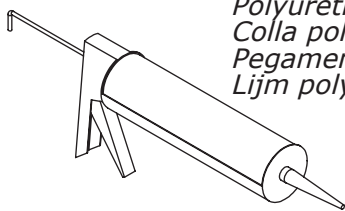

REVERSIBILITE/REVERSIBILITY/REVERSIBILITA/OMKEERBAARHEID

MONTAGE A GAUCHE
LEFT HAND
MONTAJE A LA IZQUIERDA
MONTAGE LINKS

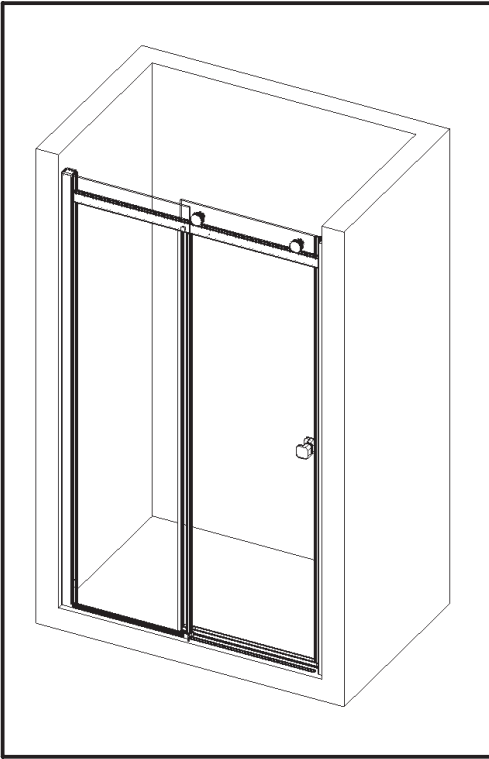

MONTAGE A DROITE
RIGHT HAND
MONTAJE A LA DERECHA
MONTAGE RECHTS

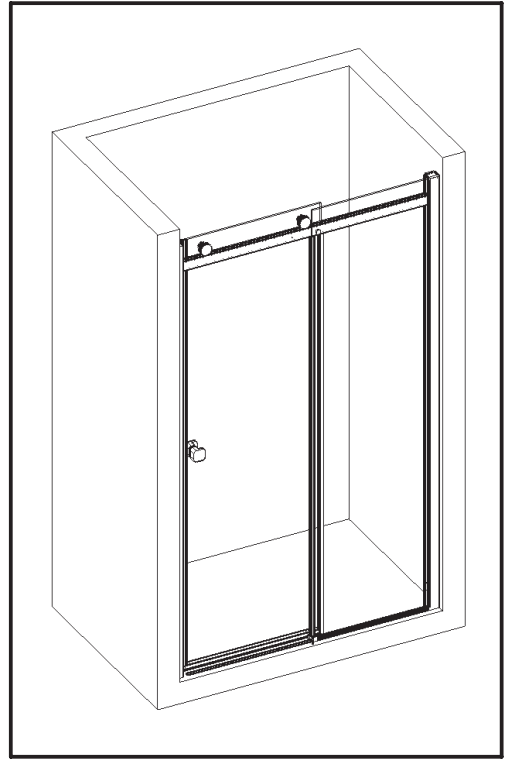

Vous avez la possibilité de réaliser un montage à droite ou un montage à gauche. Notre notice d'installation décrit un montage à gauche. si vous voulez réaliser un montage à droite, il vous suffit d'inverser le montage.

This cubicle can be installed either left or right hand. These installation instructions show a left hand installation.

Puede realizar un montaje a la derecha o un montaje a la izquierda. Nuestro folleto de instalación describe un montaje a la izquierda. Si desea montar su cabina a la derecha sólo tendrá que realizar el montaje al contrario.

U kunt de cabine rechts of links monteren. Onze handleiding beschrijft de linkse montage van de cabine. Keer de montage om als u de cabine rechts wilt monteren.



REMARQUE IMPORTANTE
NOTA IMPORTANTE
BELANGRIJKE OPMERKING
NOTA IMPORTANTE



Avant de commencer le montage, fermer l'eau.
Prima di iniziare il montaggio chiudere l'acqua.
Sluit de watertoevoer af voordat u begint met de installatie.
Antes de empezar el montaje cierre el agua.

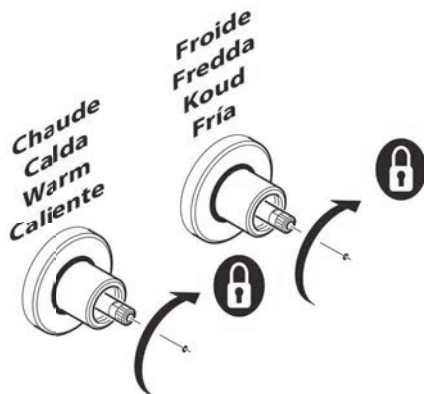
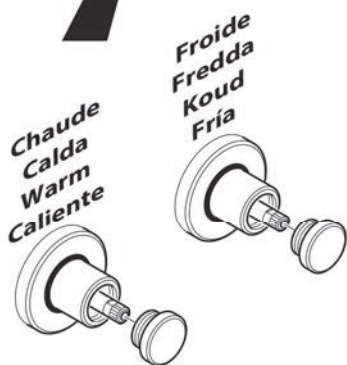
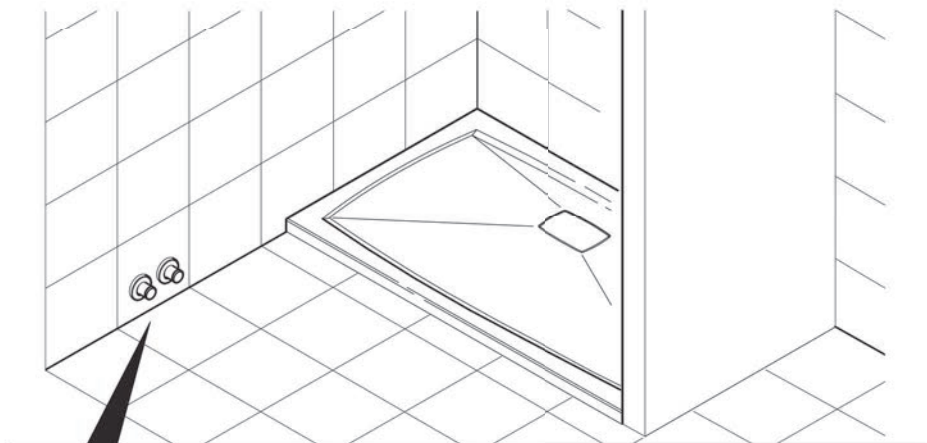



**REMARQUE IMPORTANTE - NOTA IMPORTANTE
BELANGRIJKE OPMERKING - NOTA IMPORTANTE**



**Vérifier que le receveur soit installé correctement
(Voir les instructions de montage receveur)**

La paroi de douche ne permet pas de rattrapage de niveau

**Verificare che il piatto sia installato correttamente
(Vedere istruzioni montaggio piatto)**

**Le pareti della cabina non consentono la regolazione di
eventuali dislivelli del piatto doccia**

**Zorg ervoor dat de douchebak correct is geïnstalleerd
(Zie instructies voor montage douchebak)**

**De wanden van de cabine staan geen aanpassing van de
oneffenheden in de douche toe**

**Comprobar que el plato está instalado correctamente
(Véanse las instrucciones del montaje del plato)**

**Las paredes de la cabina no permiten la regulación de las
irregularidades en la ducha**

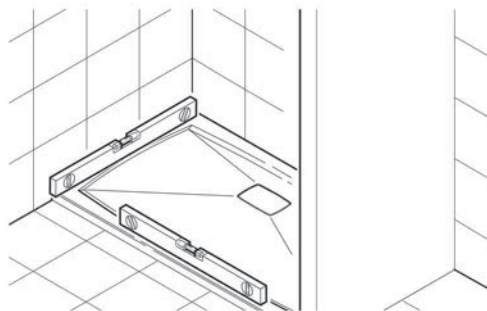

**Protéger le receveur avec du
carton ou du film à bulles**

**Proteggere il piatto con cartone
o pluriball**

**Scherm de douchebak af met
karton of noppenfolie**

**Proteger el plato con cartón o
film alveolar**

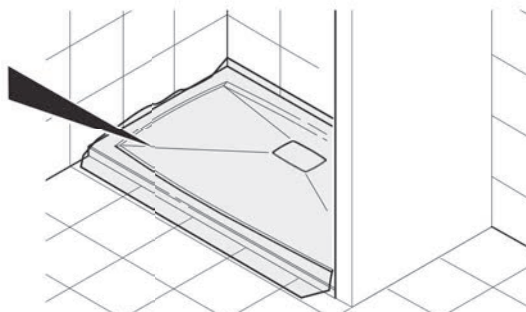

01

X6

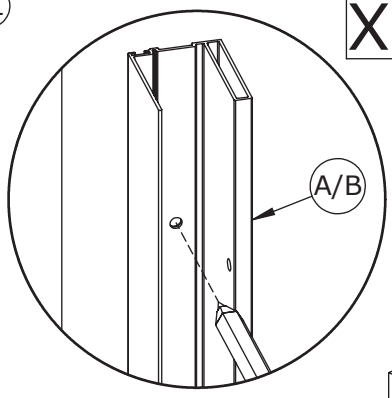

Extérieur
 Esterno
 Buitenzijde
 Externo

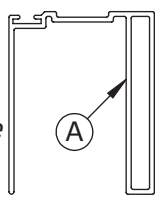

Intérieur
 Interno
 Binnenzijde
 Interno

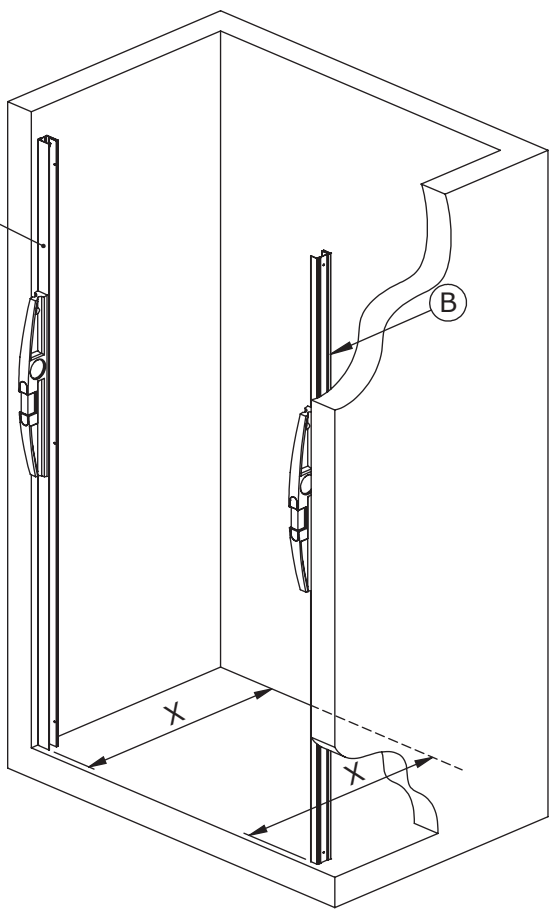

Extérieur
 Esterno
 Buitenzijde
 Externo

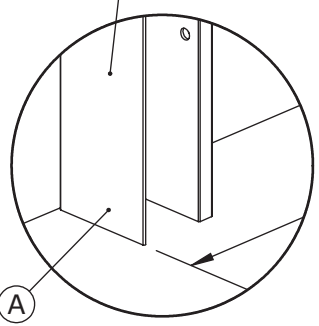

Extérieur
 Esterno
 Buitenzijde
 Externo

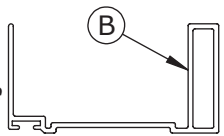

Intérieur
 Interno
 Binnenzijde
 Interno

02

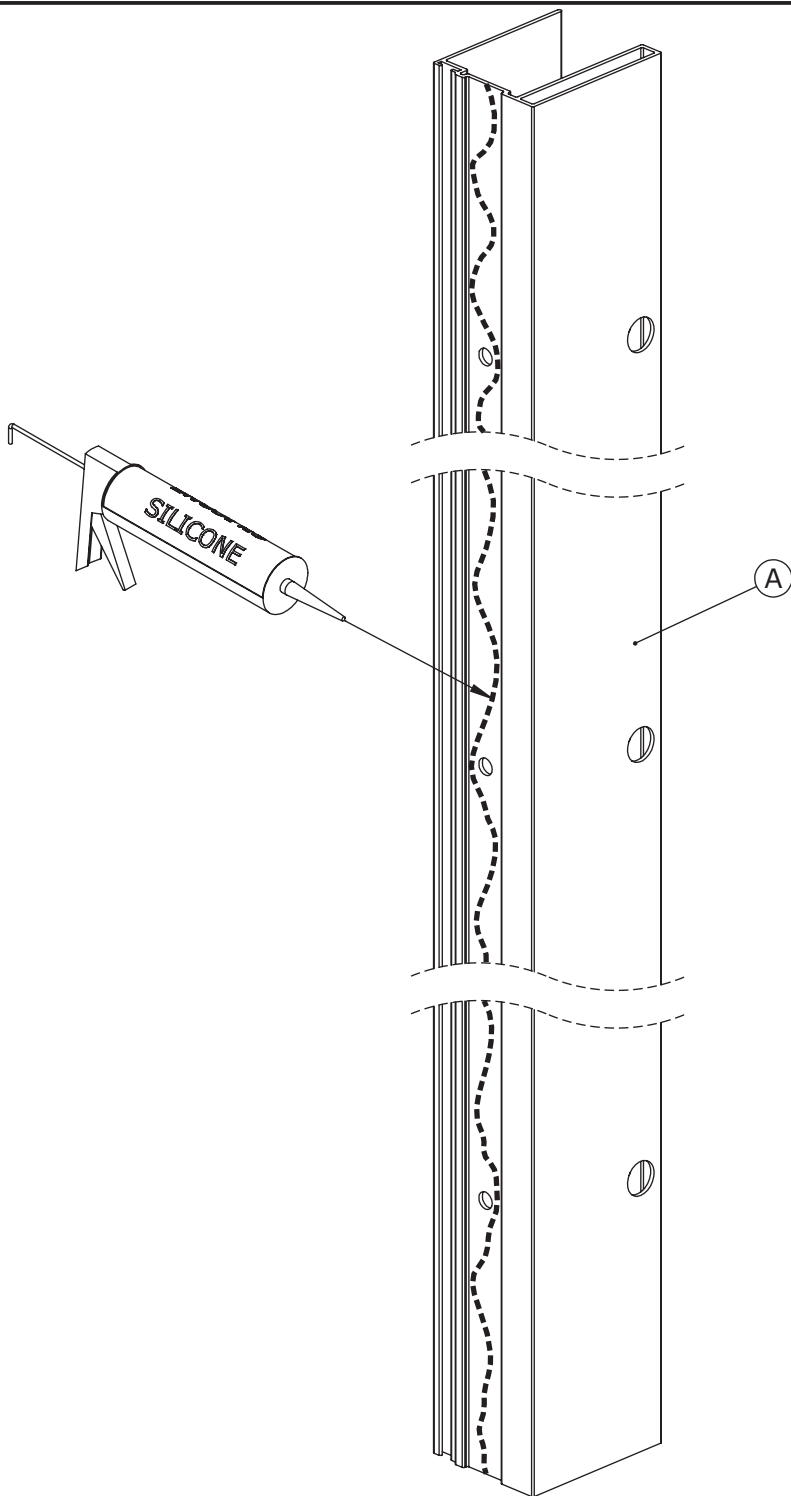

03

X3

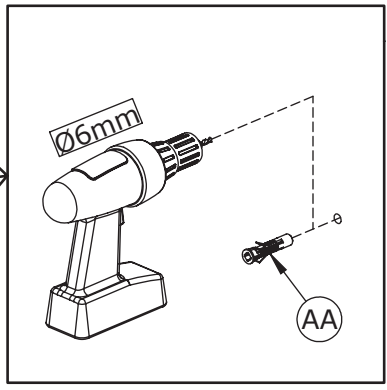
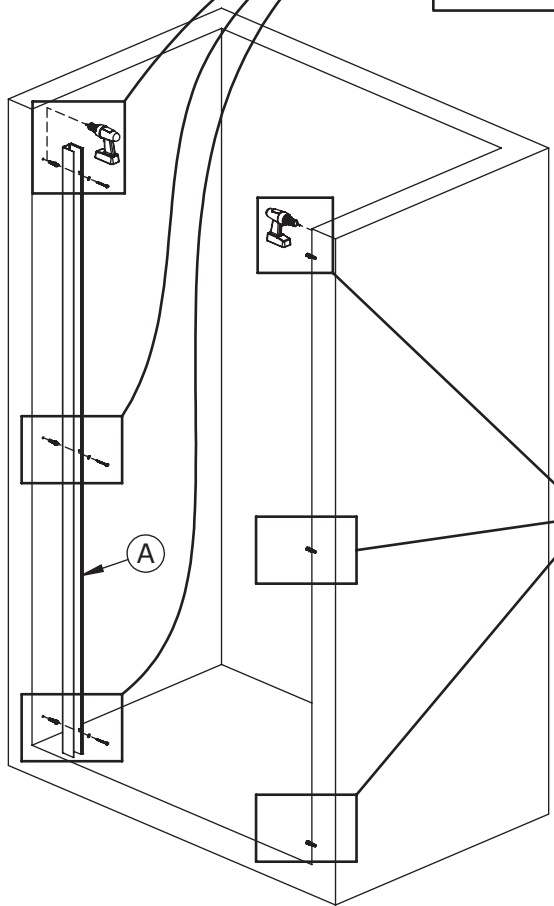
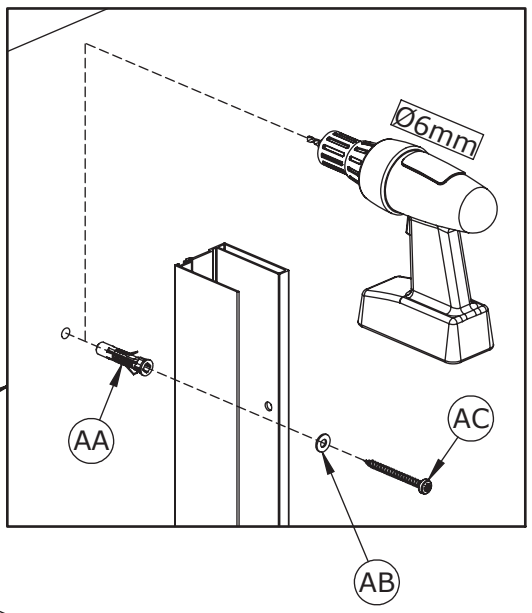

X3

04

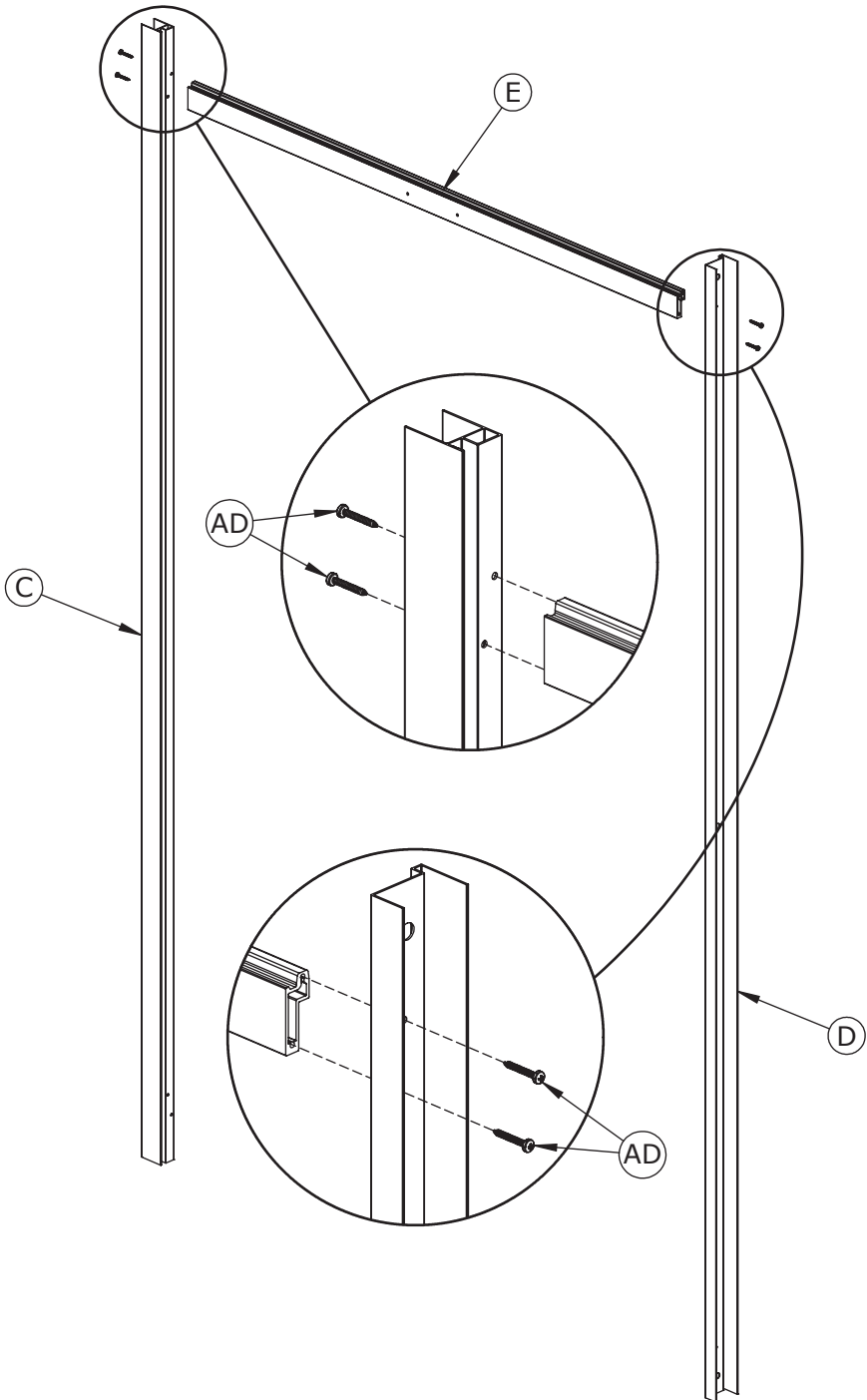

05

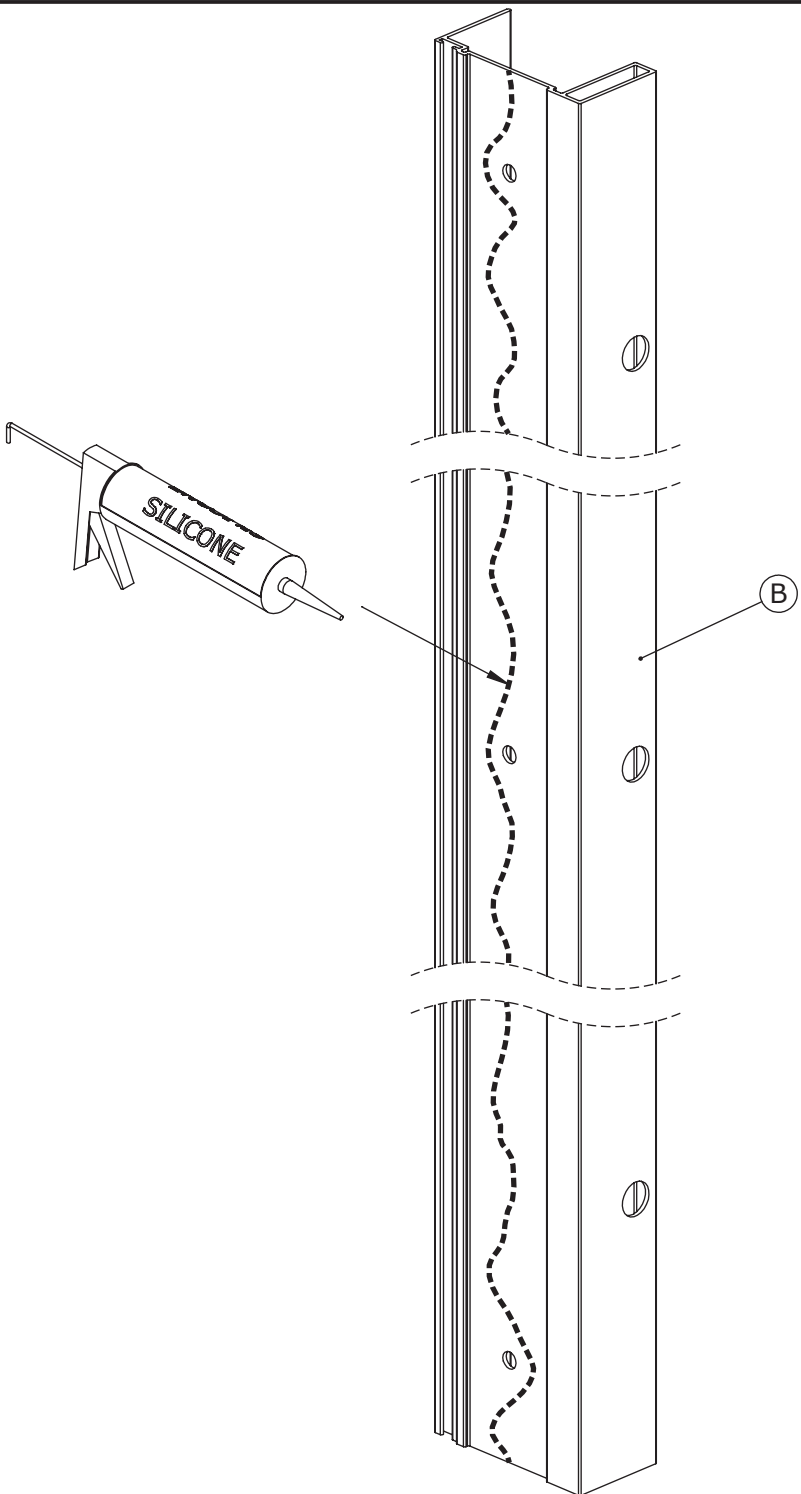

06

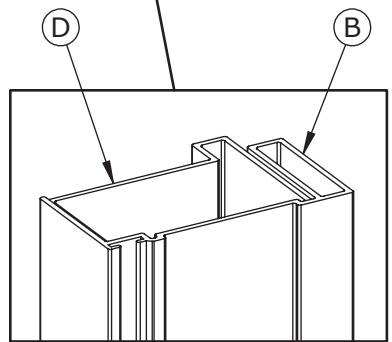
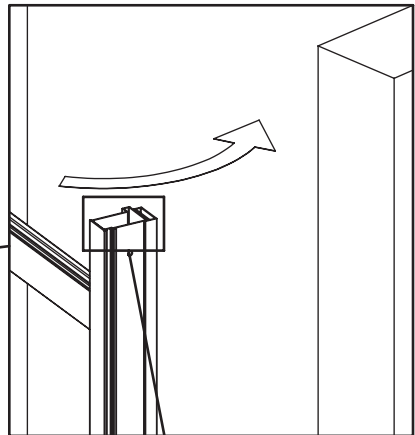
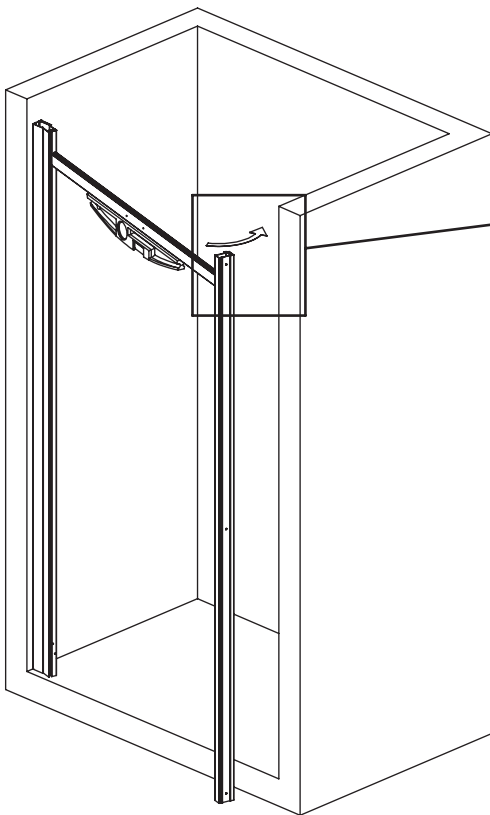

X3

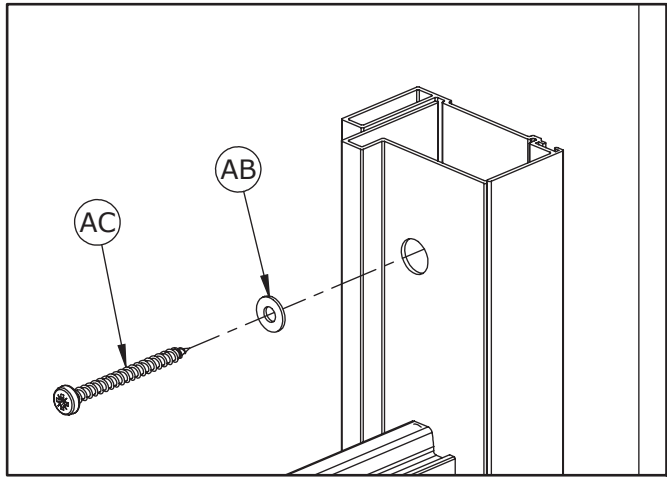

07

X6

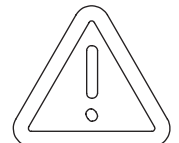
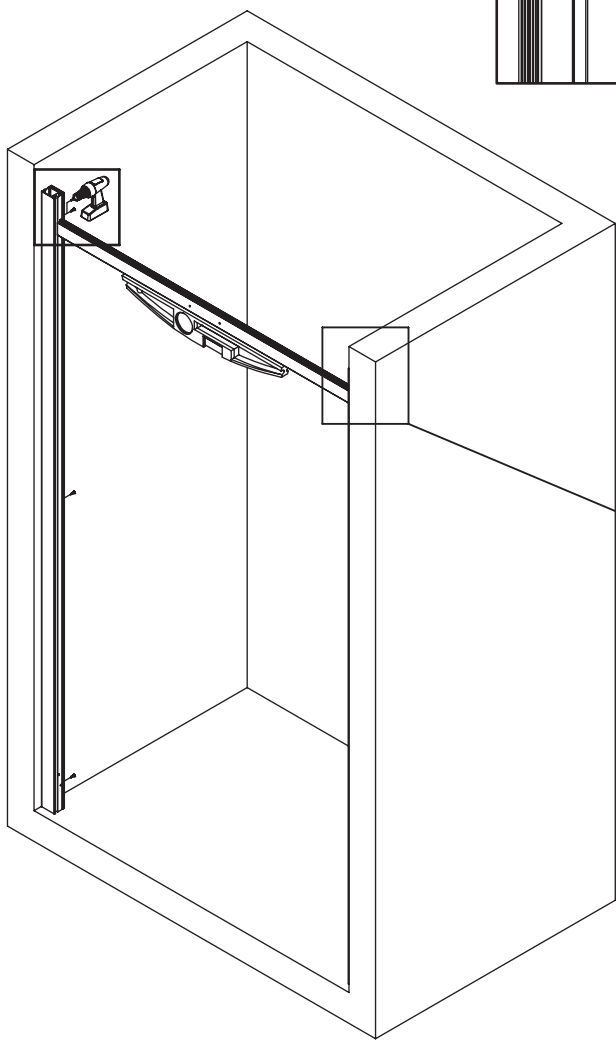
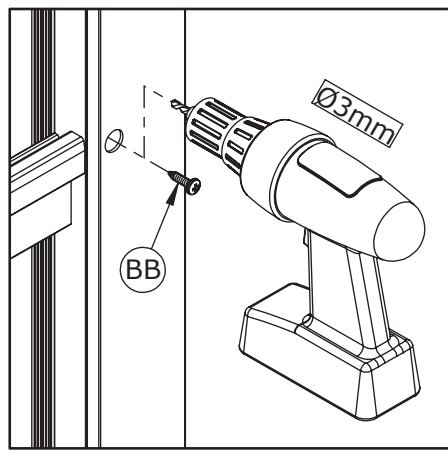

MAX 22mm

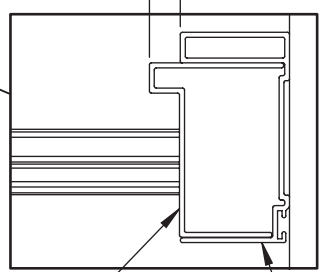

D

B

08

NE PAS SERRER
NON SERRARE
NIET VASTSCHROEVEN
NO APRIETE

X2

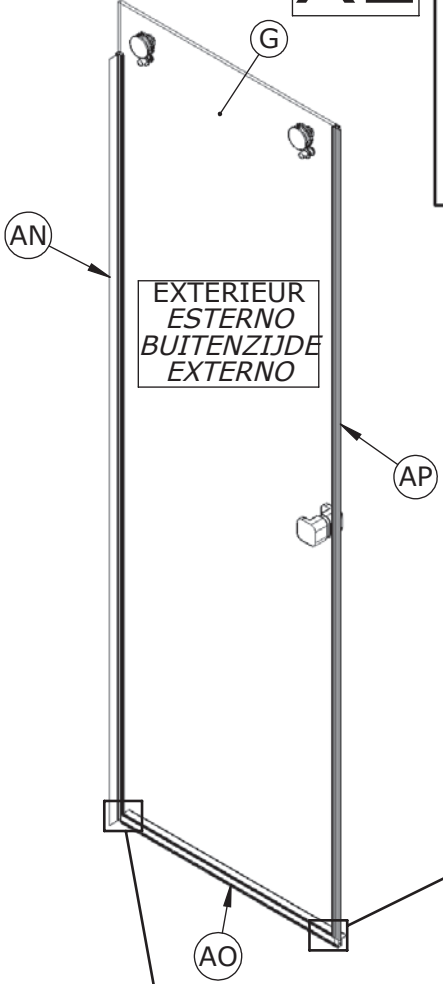
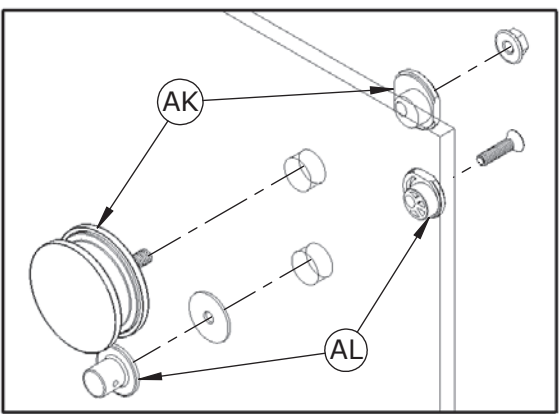

EXTERIEUR
ESTERNO
BUITENZIJD
EXTERNO

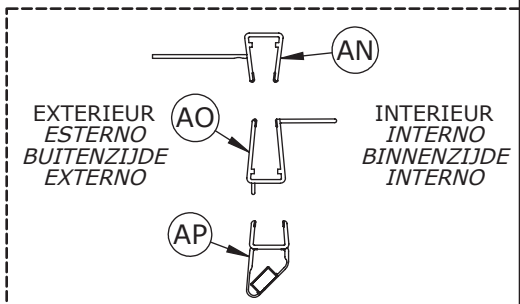
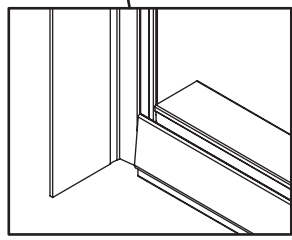
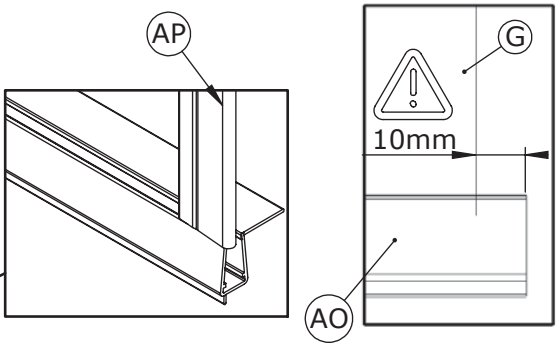
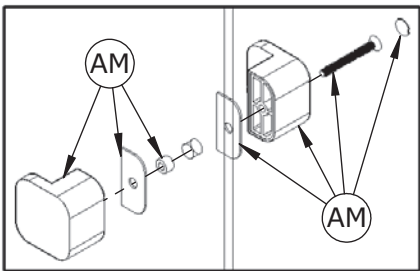



Poser la porte (G) à l'intérieur
Posizionare il vetro (G) all'interno
Colocar la puerta (G) en el interior
Plaats het glas (G) binnenzijde

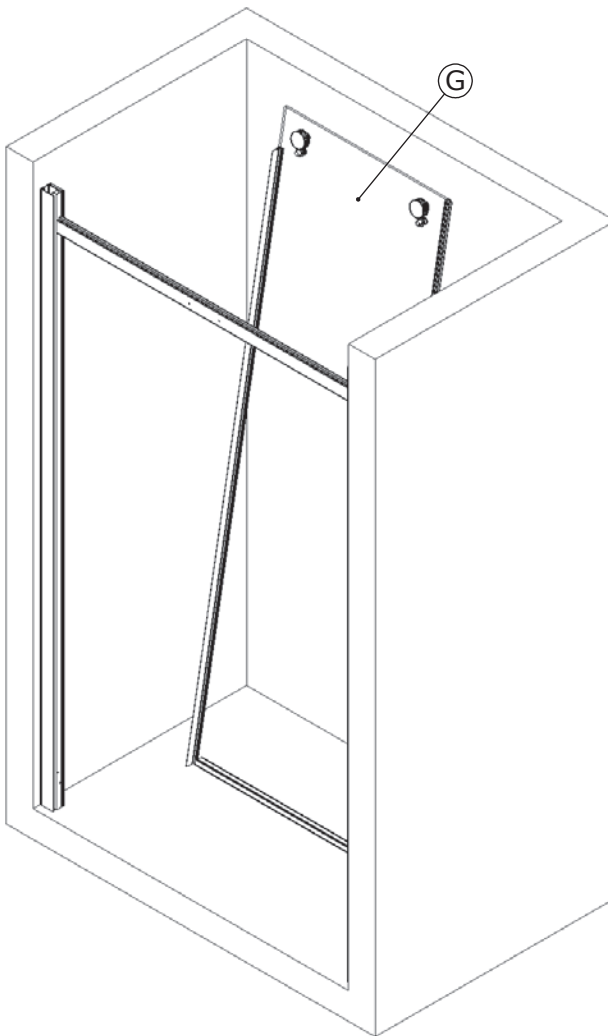

09

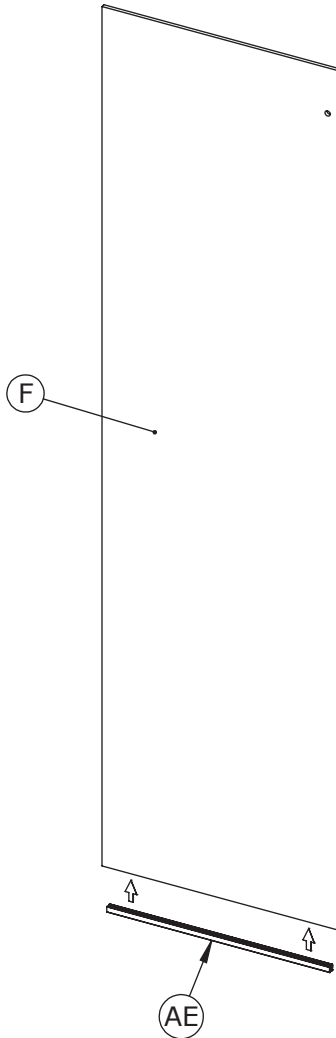
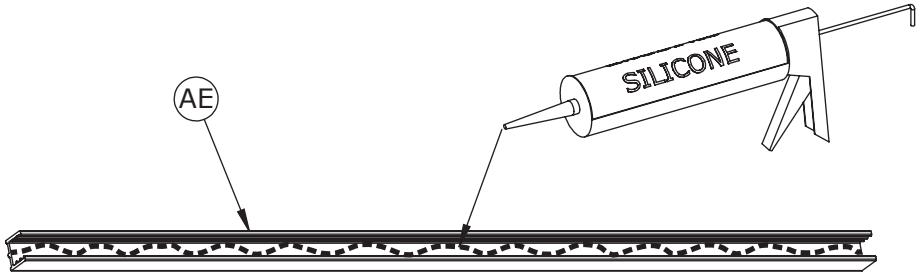

10

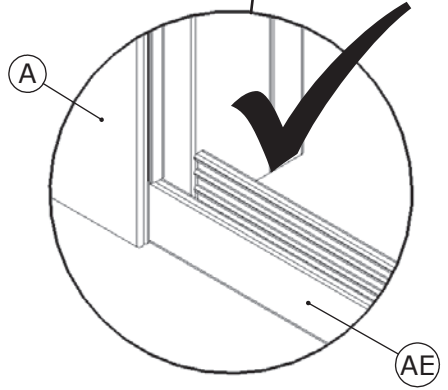
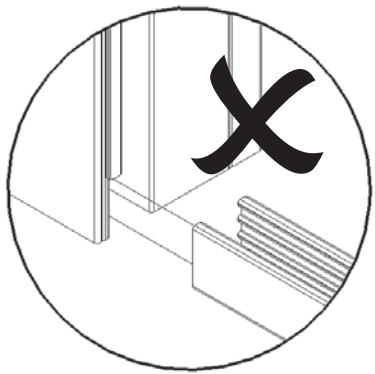
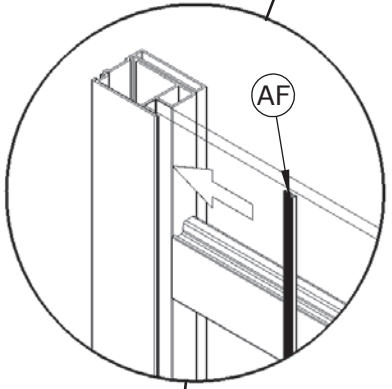
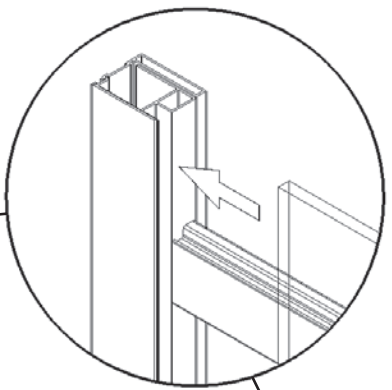
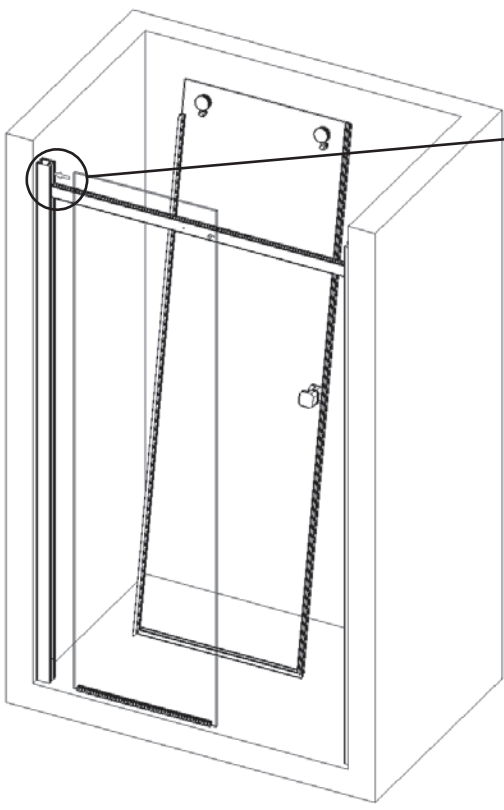

11

Pré-réglage avec excentrique
Adjustment with eccentric
Regolazione primaria con eccentrico
Eerste afstelling met excentriek
Ajustar el tornillo excéntrico sin apretar

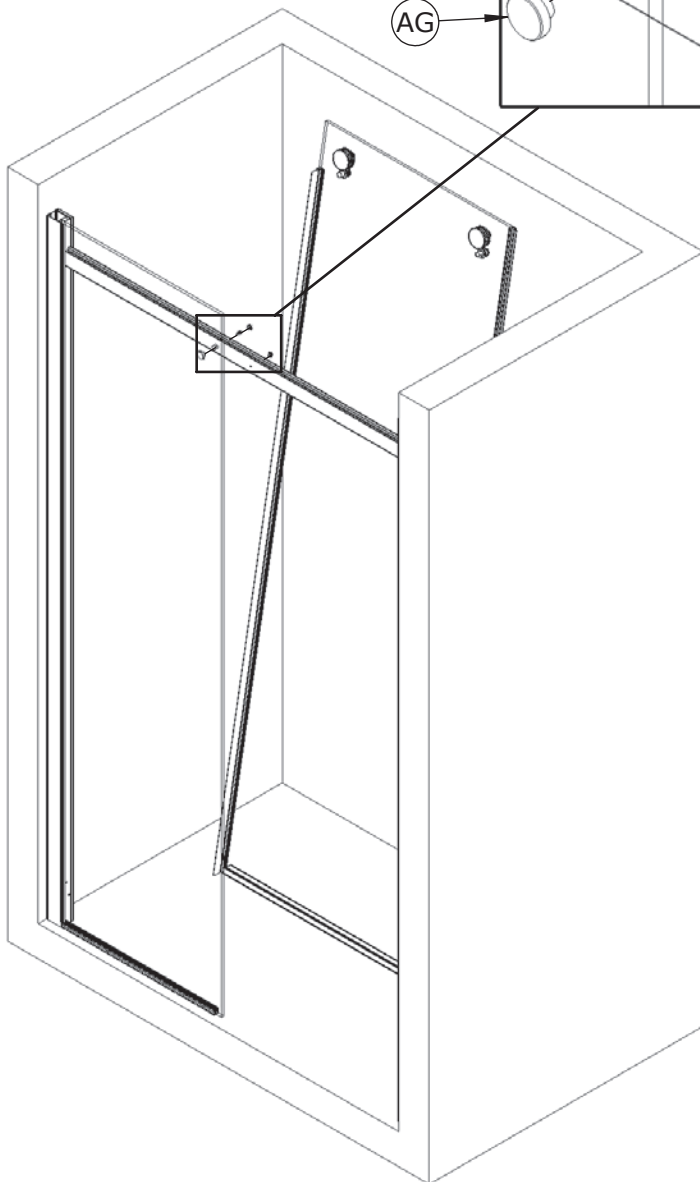
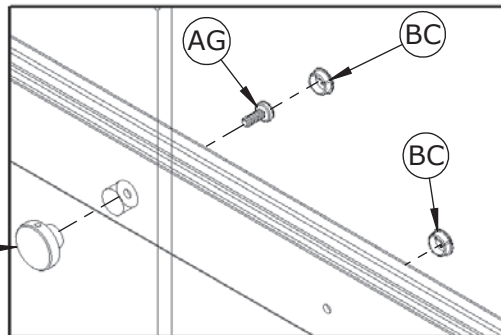

MONTAGE AVEC RECEVEUR
MONTAGGIO CON PIATTO
ASSEMBLEREN MET DOUCHEBAK
MONTAJE CON PLATO

12

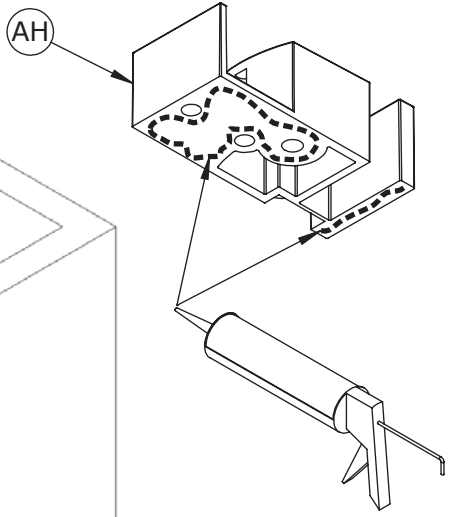
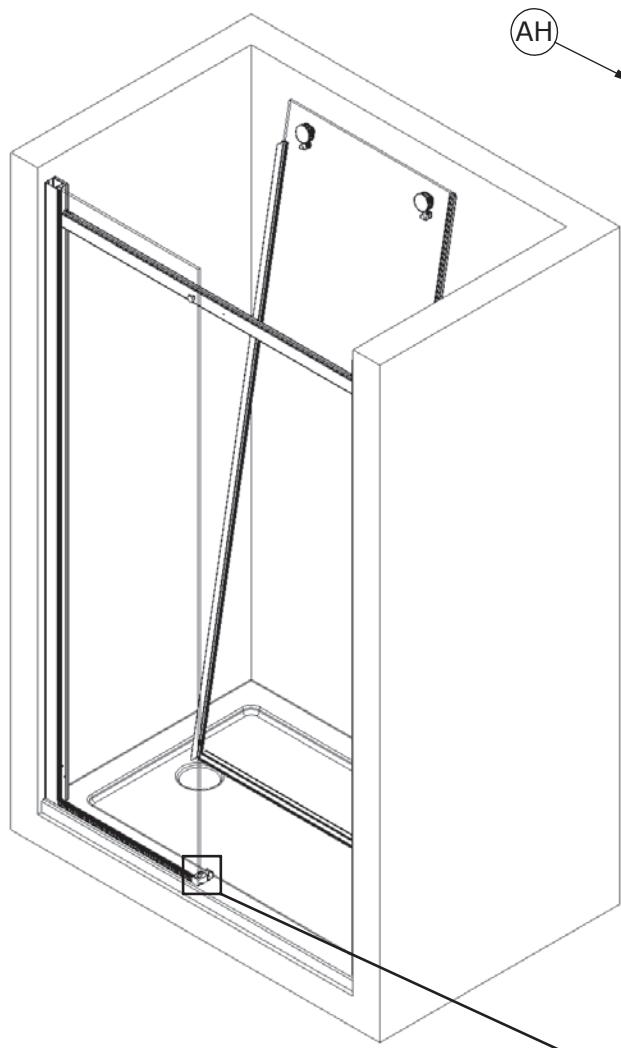

Colle polyuréthane
Colla poliuretano
Lijm polyurethaan
Pegamento poliuretano

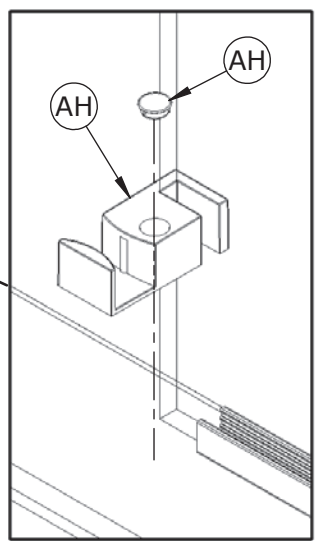

INTERIEUR
INTERNA
BINNEN
INTERIOR

MONTAGE SANS RECEVEUR
MONTAGGIO SENZA PIATTO
ASSEMBLEREN ZONDER DOUCHEBAK
MONTAJE SIN PLATO

12b

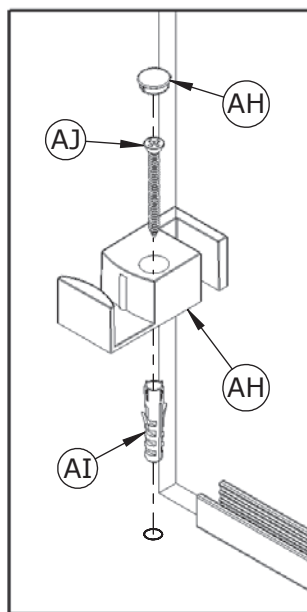
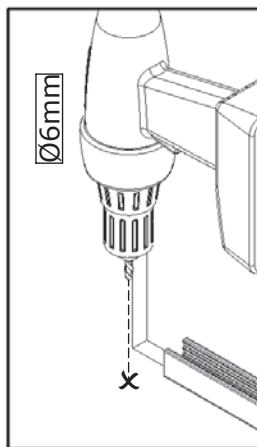
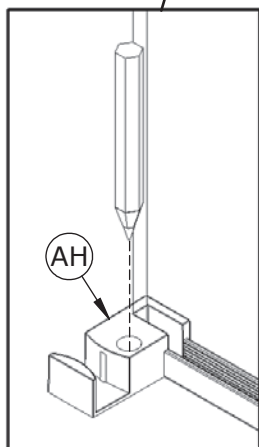
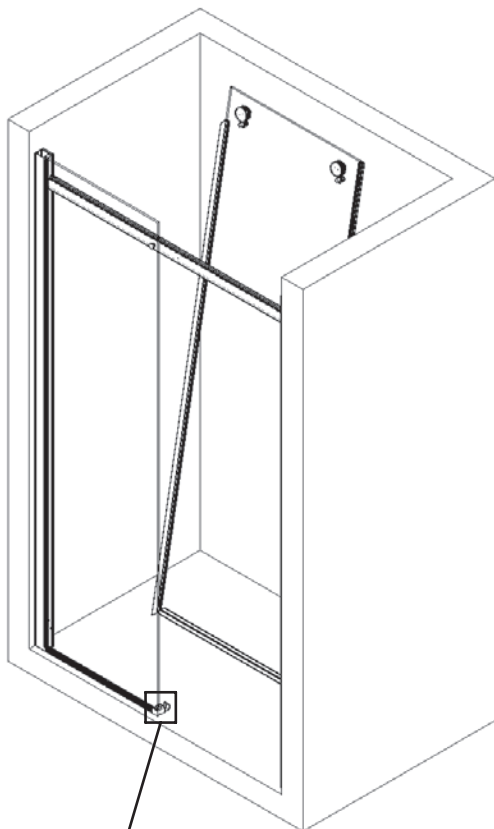

INTERIEUR - *INSIDE* - INTERNA - INTERIOR - BINNEN

13

NE PAS SERRER FORT
NON SERRARE
NIET VASTSCHROEVEN
NO APRIETE

Régler
Regolare
Stel
Ajustar

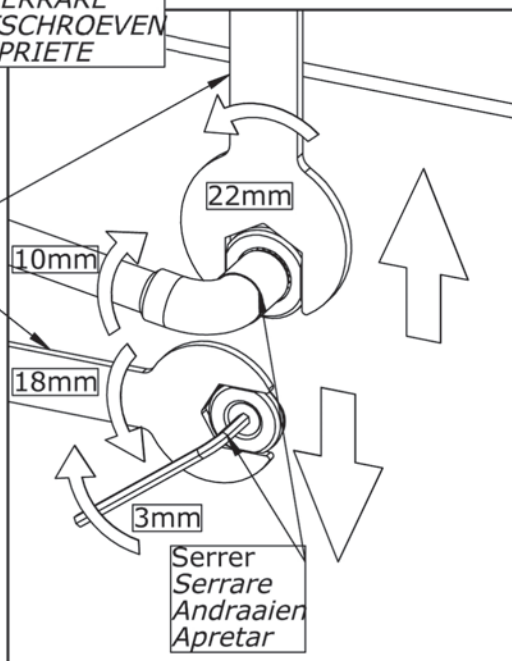

D Max



D < D Max



14

2

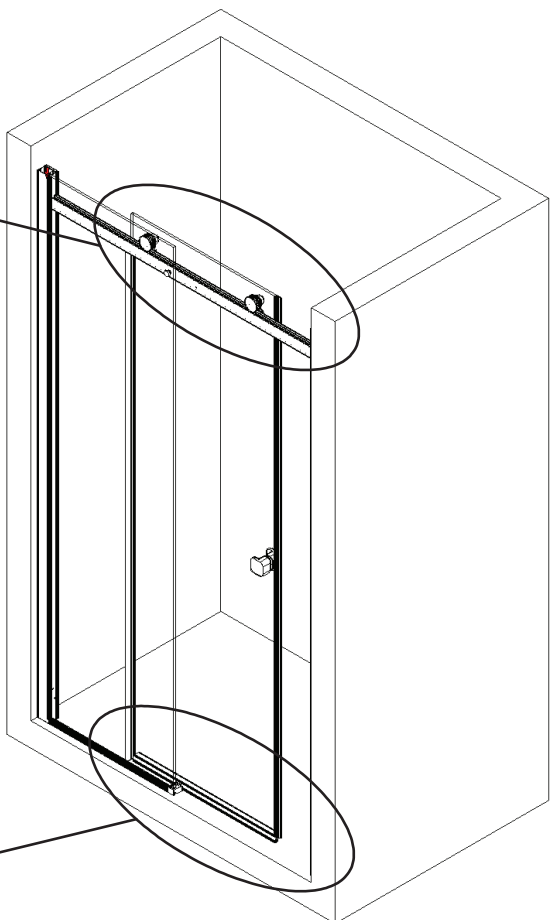
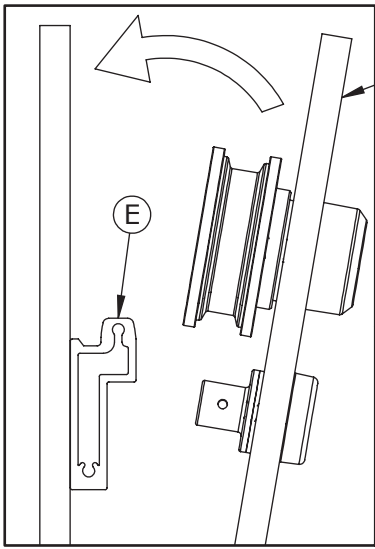

1

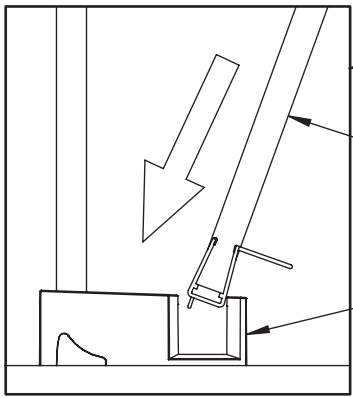

15

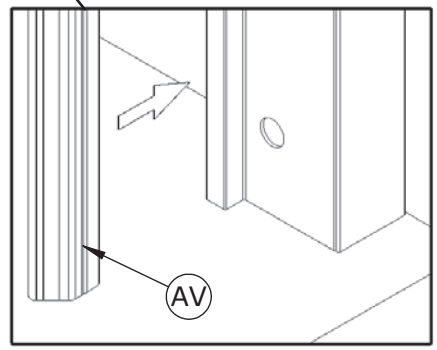
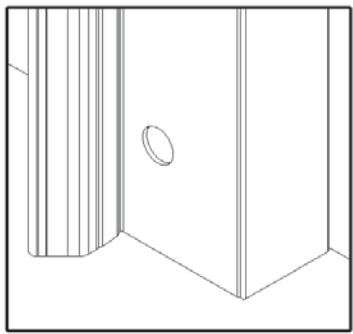
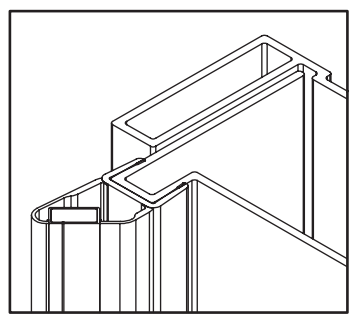
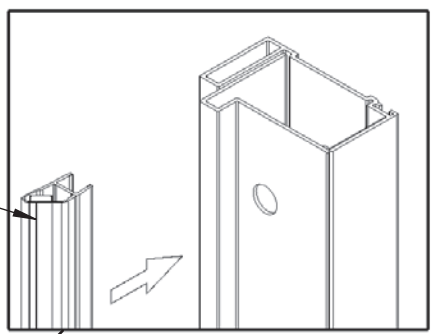
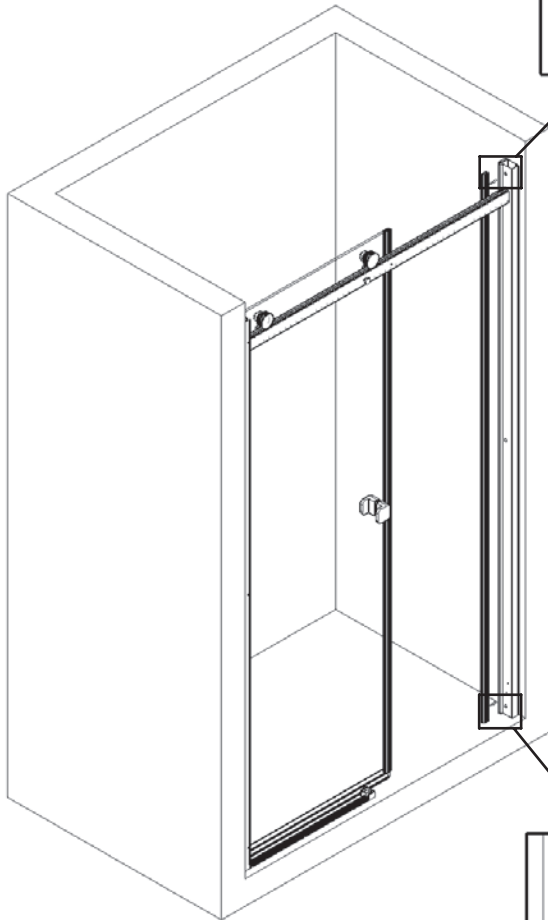

EXTERIEUR
ESTERNO
BUITENZIJDE
EXTERNO



INTERIEUR
INTERNO
BINNENZIJDE
INTERNO

16

Régler la porte
 Regolare le porte
 Stel de deuren
 Ajustar la puerta

1

SERRER
 SERRARE
 AANDRAAIEN
 APRETAR

2

SERRER
 SERRARE
 AANDRAAIEN
 APRETAR

3

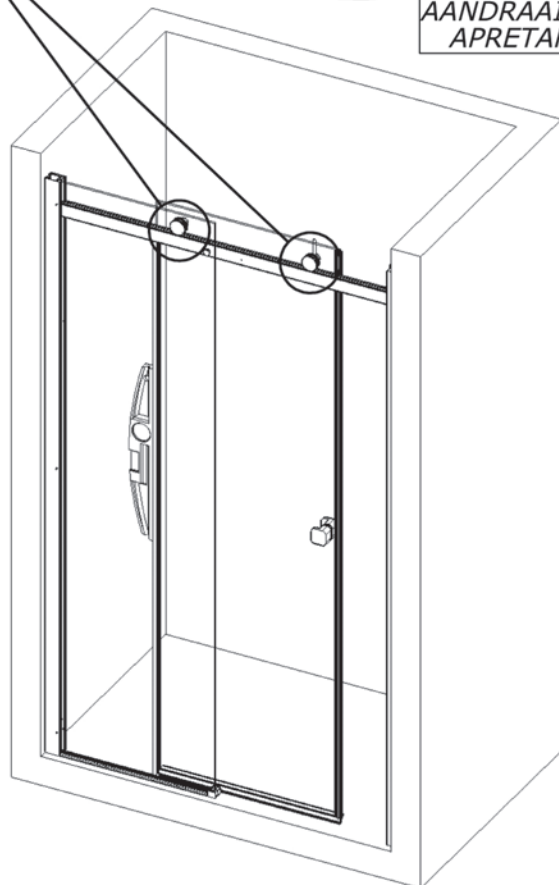

AK

AL



MIN 0,5mm
 MAX 2mm

E

17

INTERIEUR - INTERNA - BINNEN - INTERIOR

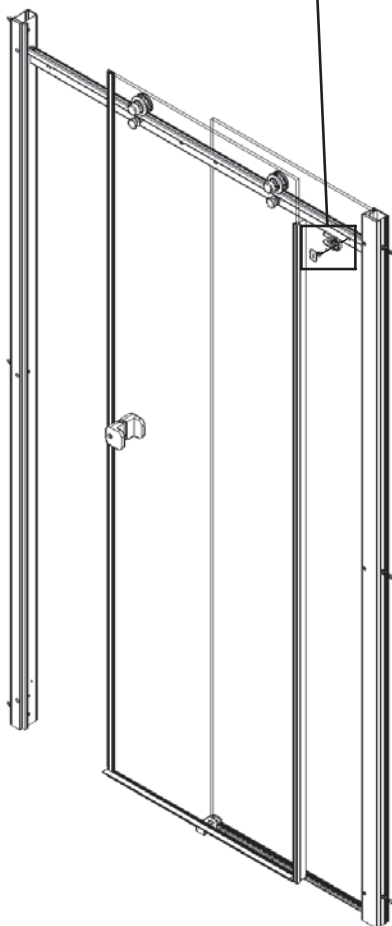
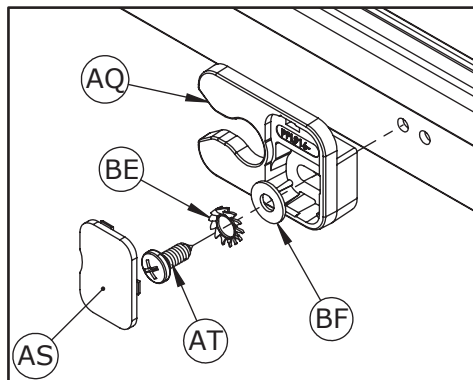

18

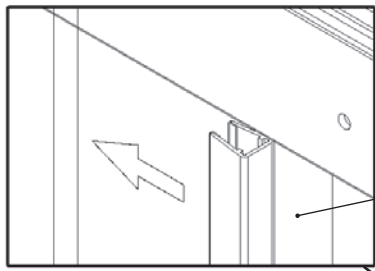

AU

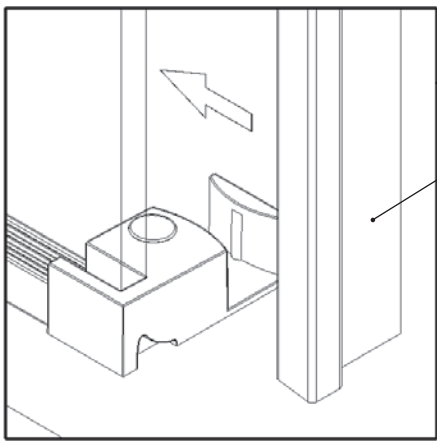
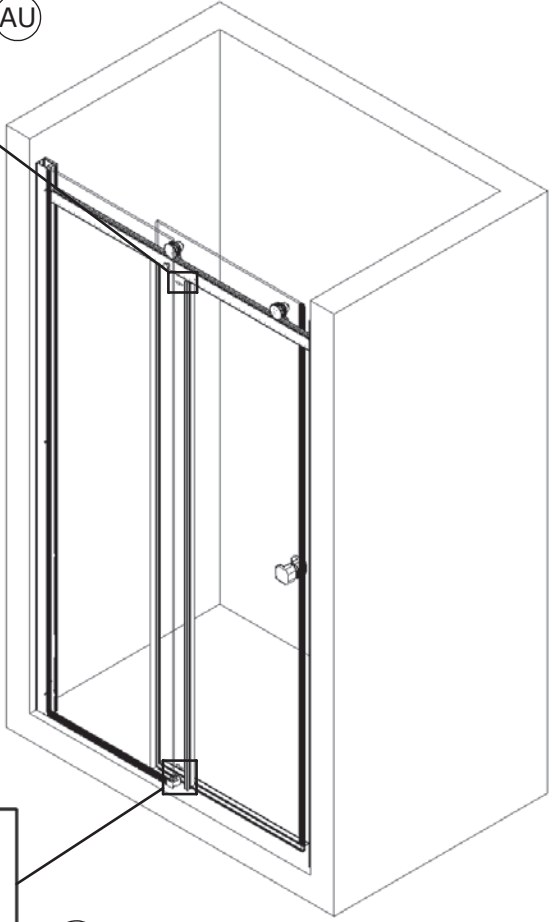
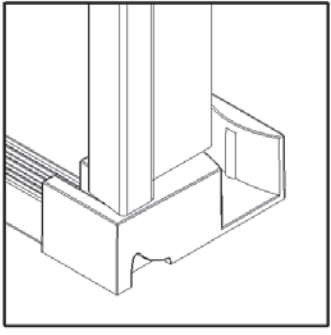
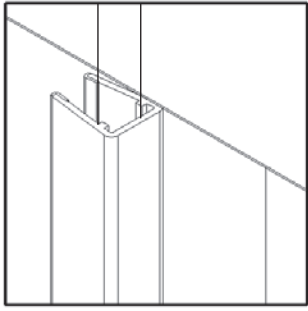

AU

EXTERIEUR
OUTSIDE
ESTERNO
EXTERNO
BUITENZIJDE

INTERIEUR
INSIDE
INTERNO
INTERNO
BINNENZIJDE

AU

19

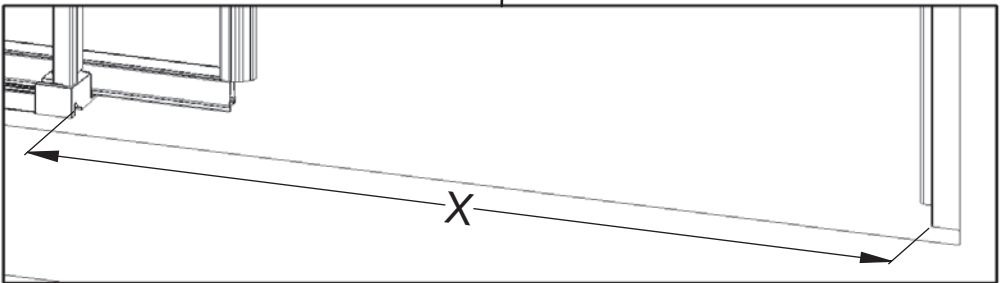
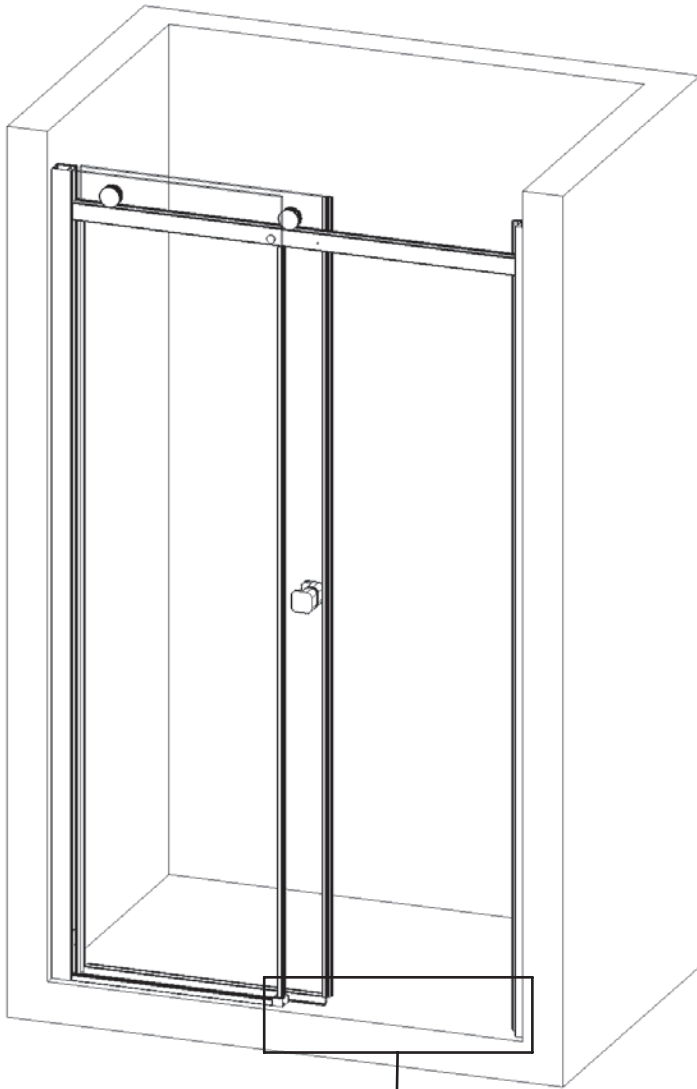

20

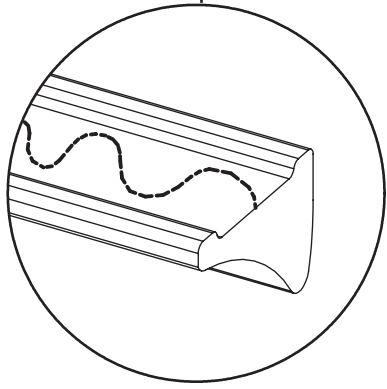
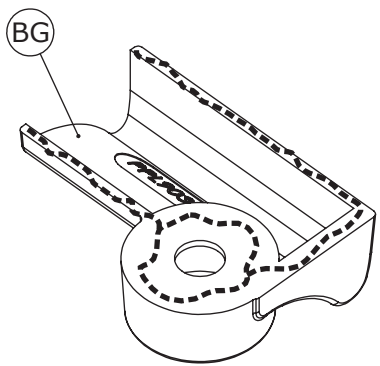
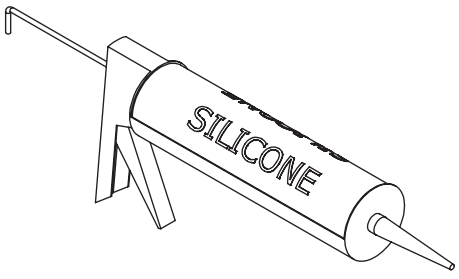
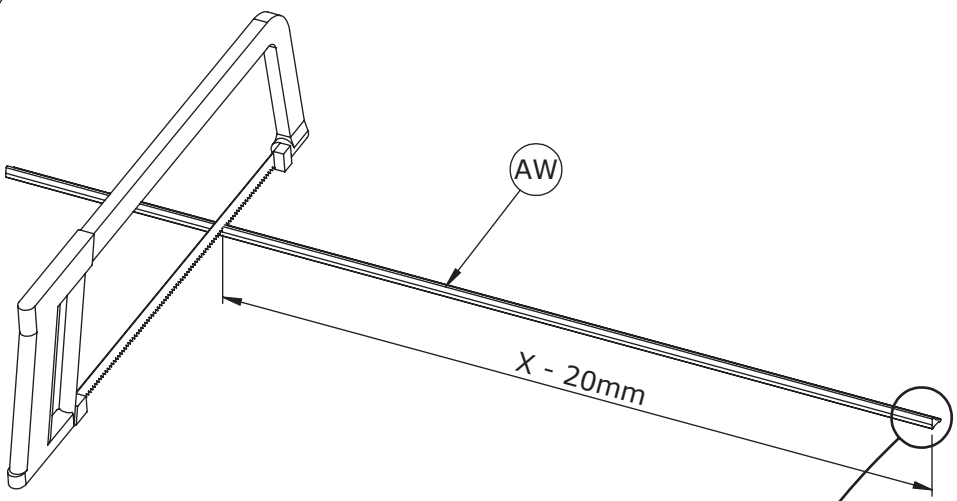

21

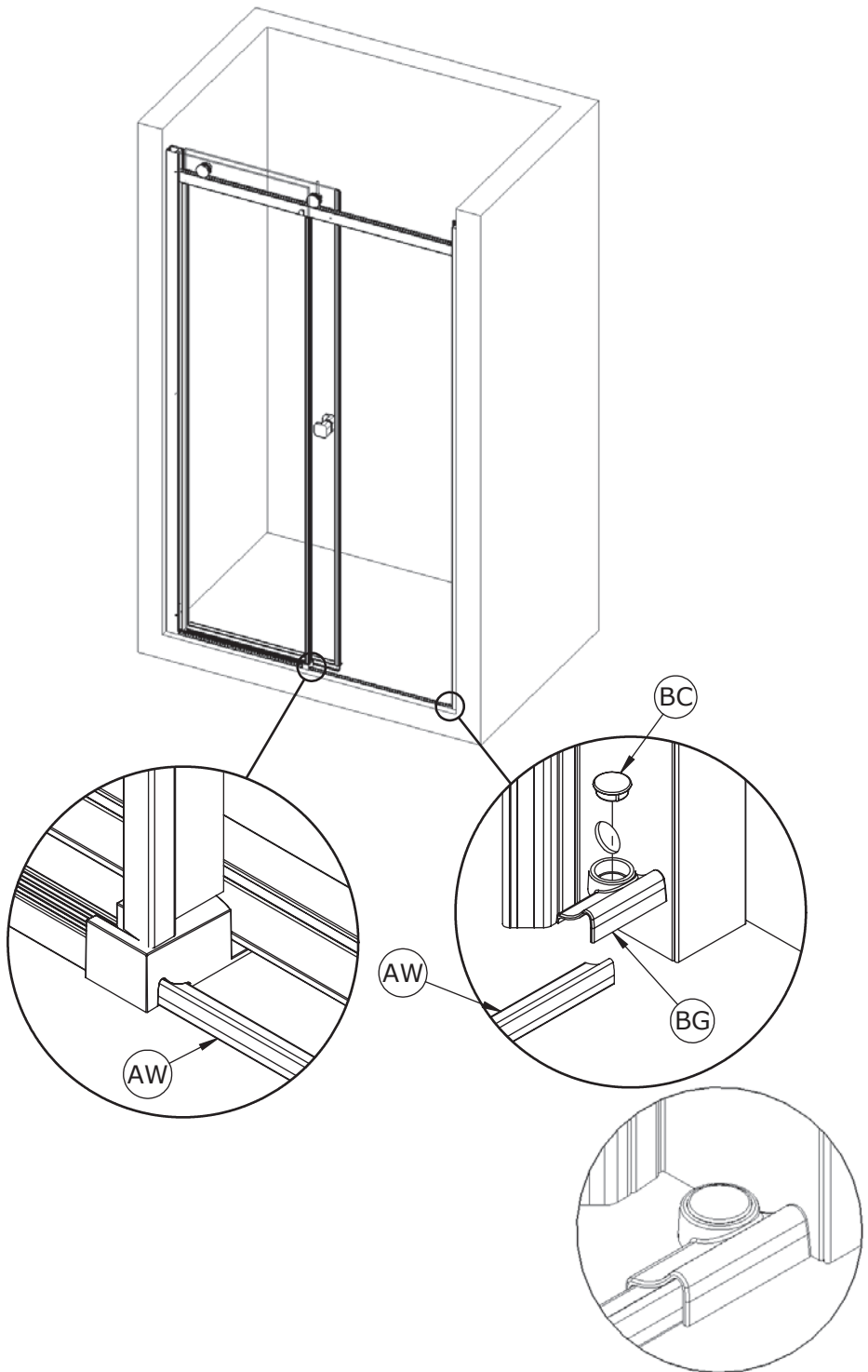

22

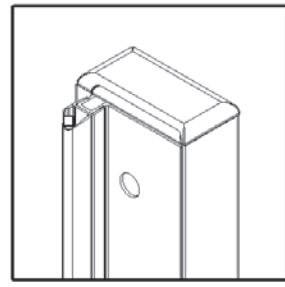
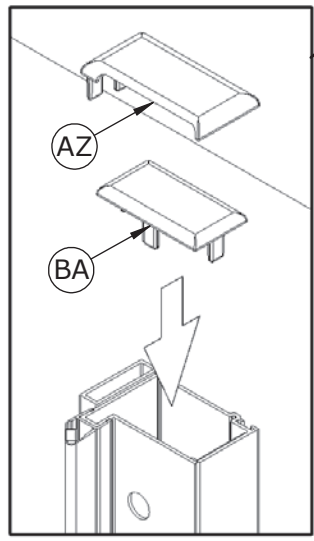
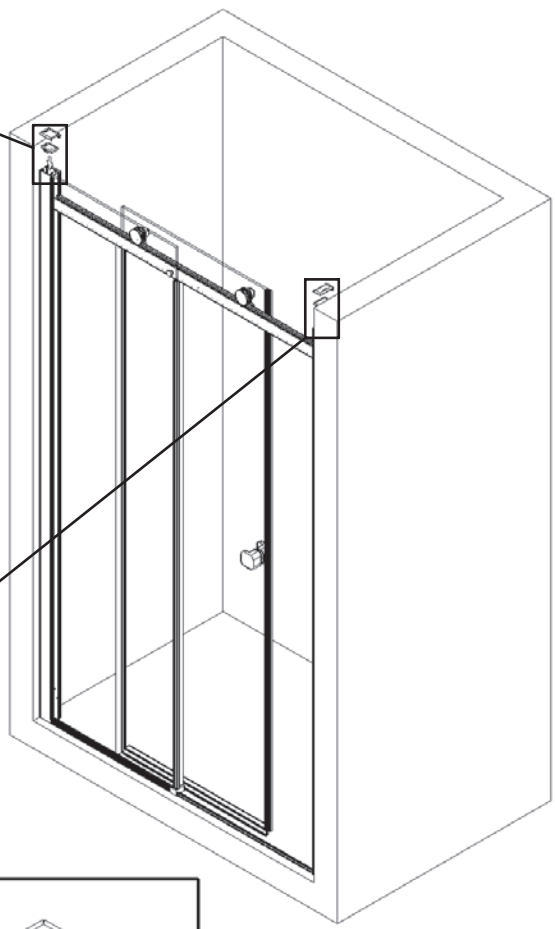
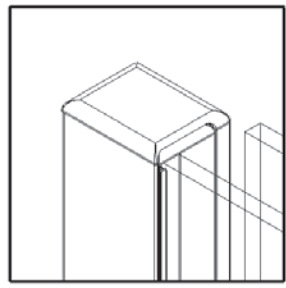
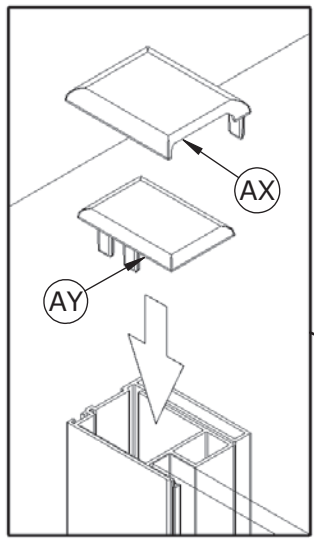

23

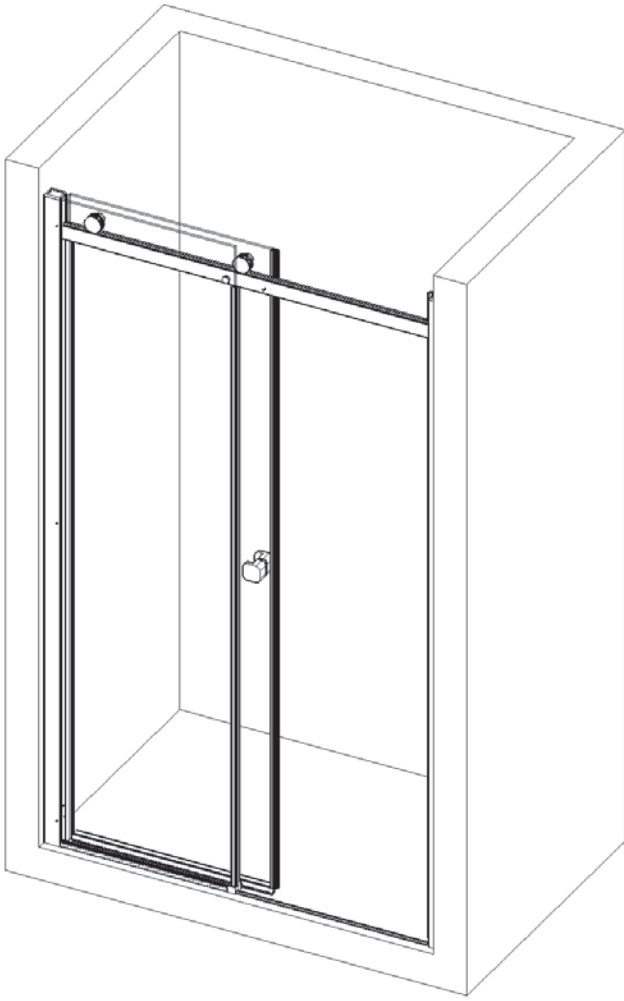

X7

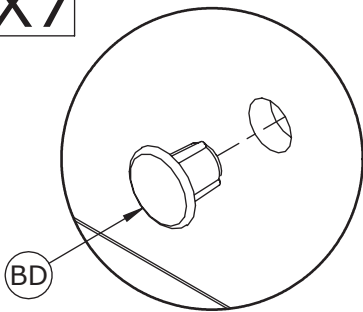

X9

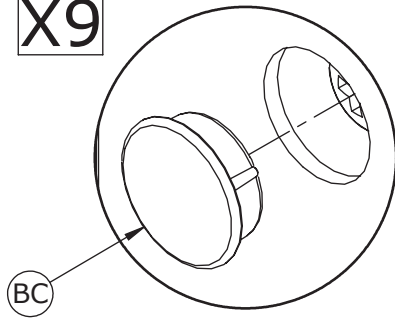

24

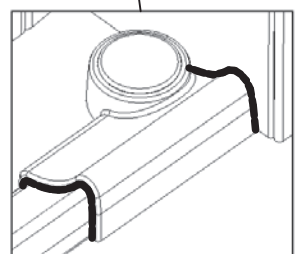
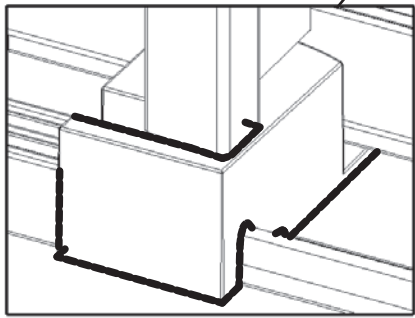
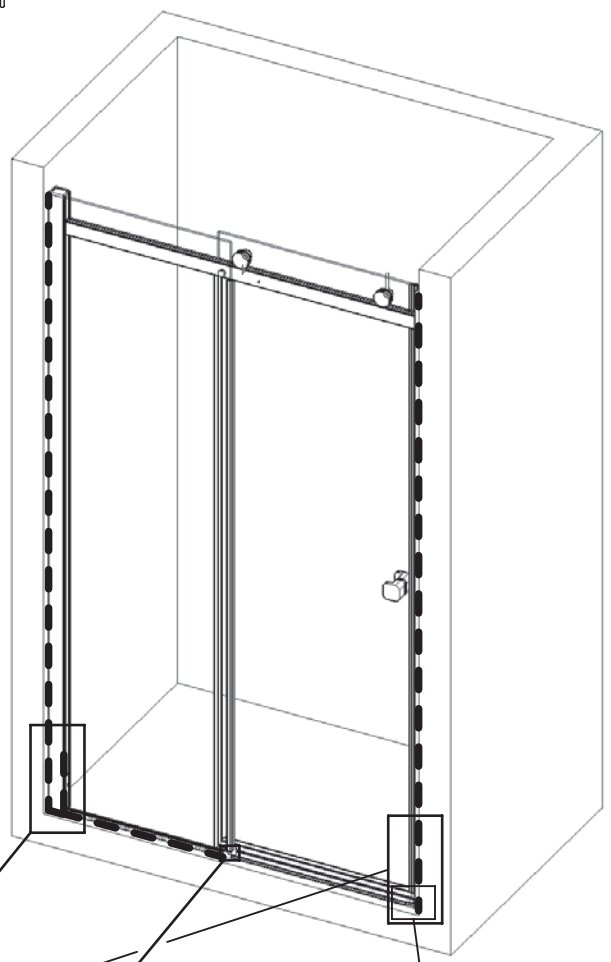
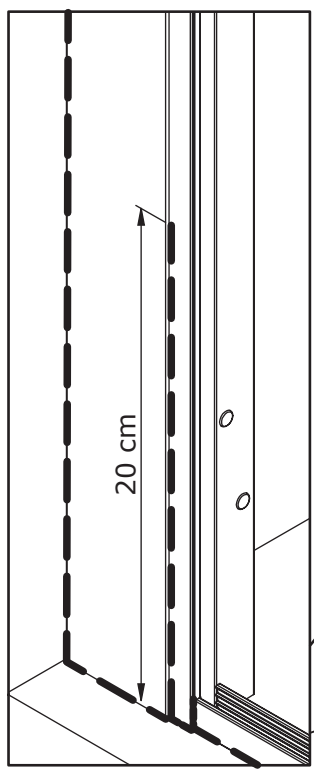

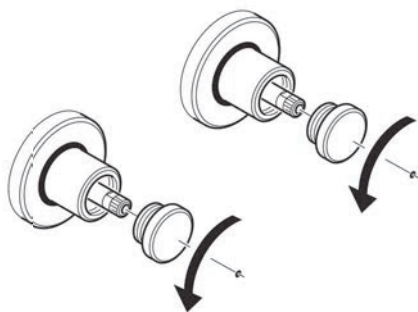
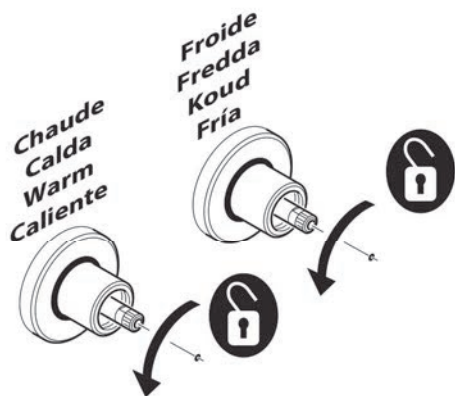
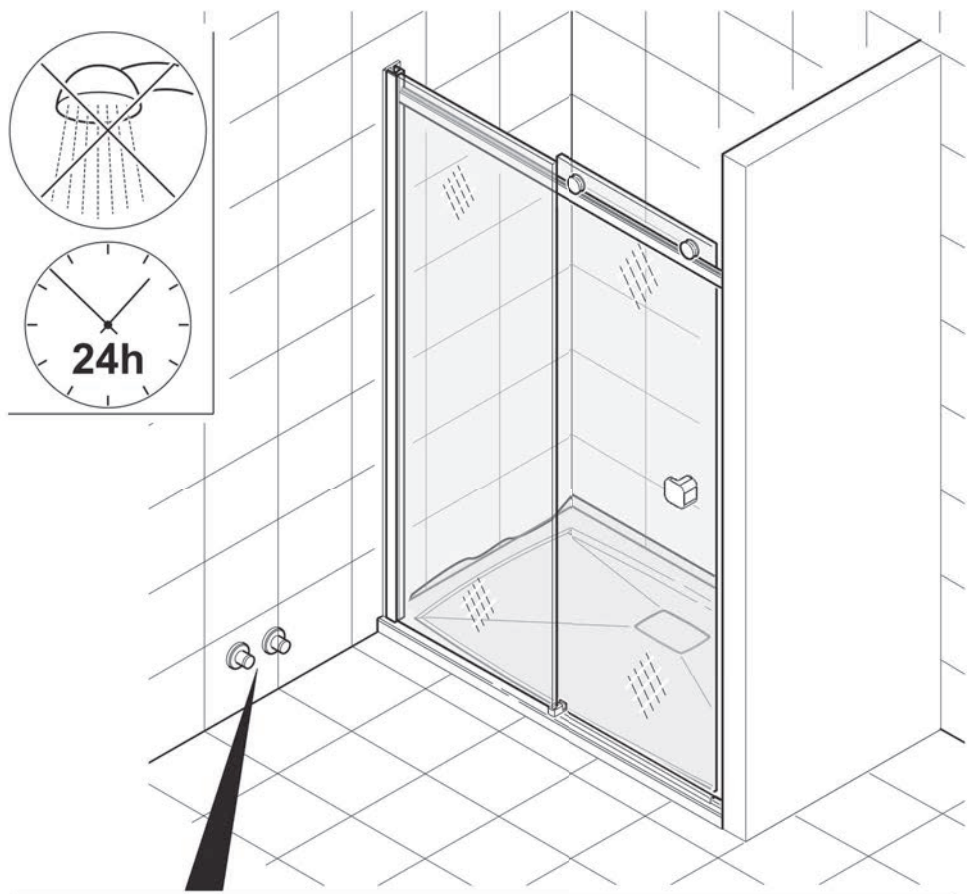

**INFORMATIONS SUR L'UTILISATION
 INFORMAZIONI SULL'UTILIZZO
 INFORMATIE OVER HET GEBRUIK
 INFORMACIONES SOBRE EL USO**

- **Ne pas mettre les mains entre les parois de verre lorsque celles-ci sont coulissées.**
- **Non mettere le mani tra le pareti in vetro mentre scorrono.**
- **Steek uw handen niet tussen de glazen wanden wanneer deze worden verschoven.**
- **No ponga las manos entre los cristales mientras se desplazan.**

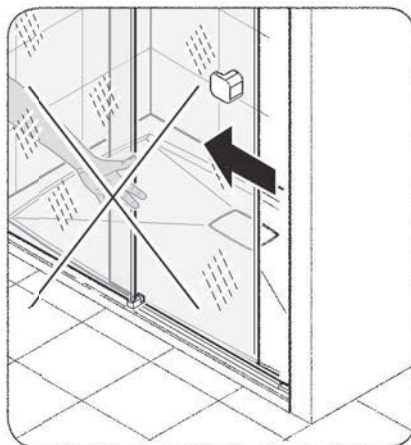

- **Ne pas s'accrocher à la fermeture de la douche.**
- **Non aggrapparsi alla chiusura doccia.**
- **Ga niet aan de douchesluiting hangen.**
- **No agarrarse al cierre de la ducha.**

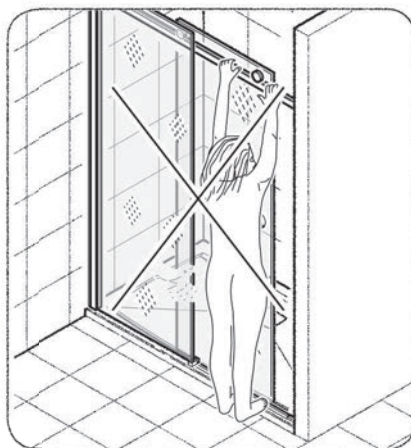

**INFORMATIONS SUR L'UTILISATION
INFORMAZIONI SULL'UTILIZZO
INFORMATIE OVER HET GEBRUIK
INFORMACIONES SOBRE EL USO**

- Ne pas suspendre d'objet lourds à la fermeture de la douche.
- Non appendere oggetti pesanti alla chiusura doccia.
- Hang geen voorwerpen aan de douchesluiting.
- No colgar objetos pesados en la ducha.

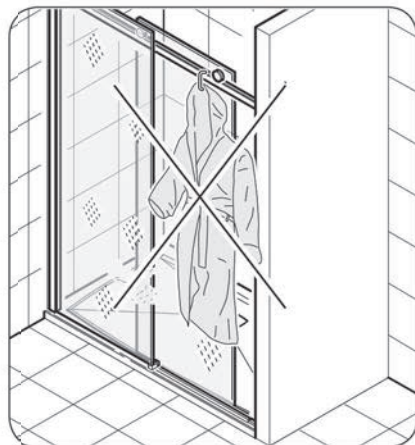

- Nettoyer périodiquement le profilé de coulissement et régler périodiquement les roulettes.
- Pulire il profilo di scorrimento e regolare le rotelle periodicamente.
- Reinig het geleiderprofiel en stel de wieltjes regelmatig af.
- Limpiar el perfil de deslizamiento y regular las ruedas periódicamente.

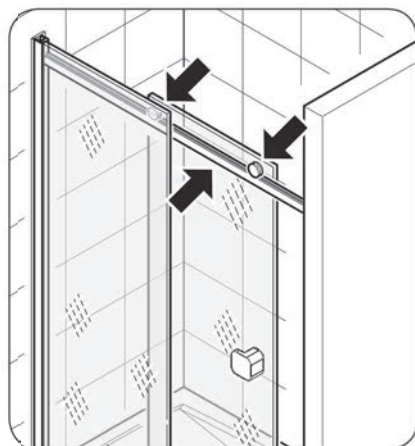

NETTOYAGE ET ENTRETIEN PULIZIA E MANUTENZIONE REINIGING EN ONDERHOUD LIMPIEZA Y MANTENIMIENTO

Nettoyage des parties chromées

Pulizia delle parti cromate

Reinigen van de verchromde onderdelen

Limpieza de las partes cromadas

- Pour nettoyer les surfaces chromées, utiliser UNIQUEMENT des détergents liquides neutres.
Pour obtenir des surfaces brillantes, appliquer périodiquement une pâte à polir avec un chiffon.

 ***Ne pas utiliser de détergents, de produits abrasifs, d'alcool, de diluants, de substances corrosives ou autres solvants.***

- Per la pulizia delle superfici cromate utilizzare SOLO detersivi liquidi neutri. Per mantenere lucide le superfici, utilizzare periodicamente un panno e del normale polish.

 ***Non utilizzare detersivi o materiali abrasivi, alcool, diluenti, sostanze corrosive o altri solventi.***

- Gebruik voor het reinigen van verchromde oppervlakken ALLEEN neutrale reinigingsmiddelen.
Om de verchromde oppervlakken glanzend te houden, gebruik regelmatig een doek en conventioneel schoonmaakmiddel.

 ***Gebruik geen schoonmaakmiddelen of schurende materialen, alcohol, verdunners, oplosmiddelen of andere bijtende stoffen.***

- Para la limpieza de las superficies cromadas utilizar ÚNICAMENTE detergentes líquidos neutros.
Para mantener lúcidas las superficies, utilizar periódicamente un paño y un pulimento normal.

 ***No utilizar detergentes ni materiales abrasivos, alcohol, diluyentes, sustancias corrosivas ni otros disolventes.***

NETTOYAGE ET ENTRETIEN PULIZIA E MANUTENZIONE REINIGING EN ONDERHOUD LIMPIEZA Y MANTENIMIENTO

Nettoyage des vitres

Pulizia dei cristalli

Reinigen van het glas

Limpieza de los cristales

- Il est conseillé de nettoyer périodiquement de manière approfondie les vitres fixes et la porte.
 - Nettoyage journalier
Rincer abondamment à l'eau froide puis essuyer avec un raclette.
 - Nettoyage périodique
Nettoyer régulièrement à l'aide d'une éponge non-abrasive et de vinaigre blanc, puis essuyer avec un chiffon doux.



 *Pour déposer la porte ou la vitre fixe, procéder à l'inverse de la procédure illustrée dans ce manuel.*

- Periodicamente si consiglia di effettuare un'accurata pulizia dei cristalli fissi e della porta.
 - Pulizia giornaliera
Risciacquare abbondantemente con acqua fredda e asciugare con una racla in gomma.
 - Pulizia periodica
Pulire regolarmente con una spugna non abrasiva e dell'aceto bianco, quindi asciugare con un panno morbido.

 *Se dovesse essere necessario rimuovere la porta o il cristallo fisso, operare in senso inverso a quanto illustrato nel presente manuale.*

NETTOYAGE ET ENTRETIEN PULIZIA E MANUTENZIONE REINIGING EN ONDERHOUD LIMPIEZA Y MANTENIMIENTO

- Het is raadzaam de glazen wanden en deuren regelmatig en zorgvuldig te reinigen.

- Dagelijkse schoonmaak

Rijkelijk afspoelen met koud water en vervolgens schoonvegen met een raamwisser.

- Periodieke reiniging

Schoonmaken met behulp van een niet-schurende spons en met schoonmaak azijn, daarna schoonvegen en afdrogen met een zachte doek.



⚠ Als u de deur of het vaste glas dient te verwijderen, ga dan omgekeerd te werk t.o.v. wat is aangegeven in deze handleiding.

- Periódicamente, se aconseja realizar una limpieza precisa de los cristales fijos y de la puerta.

Para la limpieza, utilizar detergentes comunes para vidrios y cristales.

- Limpieza diaria

Aclarar abundantemente con agua fría y secar con una rasqueta.

- Limpieza periodica

Limpiar con una esponja suave o una bayeta y con vinagre blanco y secar con una gamuza.

⚠ Si fuese necesario quitar la puerta o el cristal fijo, opere en sentido inverso a lo ilustrado en este manual.

NETTOYAGE ET ENTRETIEN PULIZIA E MANUTENZIONE REINIGING EN ONDERHOUD LIMPIEZA Y MANTENIMIENTO

Nettoyage de la bonde

Pulizia piletta di scarico

Reinigen van douche-afvoer

Limpieza del desagüe

- Retirer périodiquement le bouchon de la bonde de vidage et vérifier que le bol placé en dessous soit propre.
Éliminer d'éventuels résidus (cheveux, fils, etc.) et remettre en place.
Selon le modèle, reportez-vous au manuel de la receveur.
- Periodicamente rimuovere il tappo della piletta di scarico e controllare che il bicchiere sottostante sia pulito.
Rimuovere eventuali residui (peli, fili, etc) e riposizionare il tutto.
A seconda del modello, consultare il manuale del piatto doccia.
- Verwijder regelmatig het dekseltje van de douche-afvoer en controleer of het onderliggende vaatje schoon is.
Verwijder eventuele resten (haren, draden, enz.) en plaats alle onderdelen terug.
Afhankelijk van het model, zie de handleiding van de douchebak.
- Periódicamente, quitar el embellecedor del desagüe y controlar que el vaso del desagüe esté limpio.
Quitar los posibles residuos (pelos, hilos, etc.) y volver a colocar todo.
Según el modelo, consulte el manual del plato de ducha.

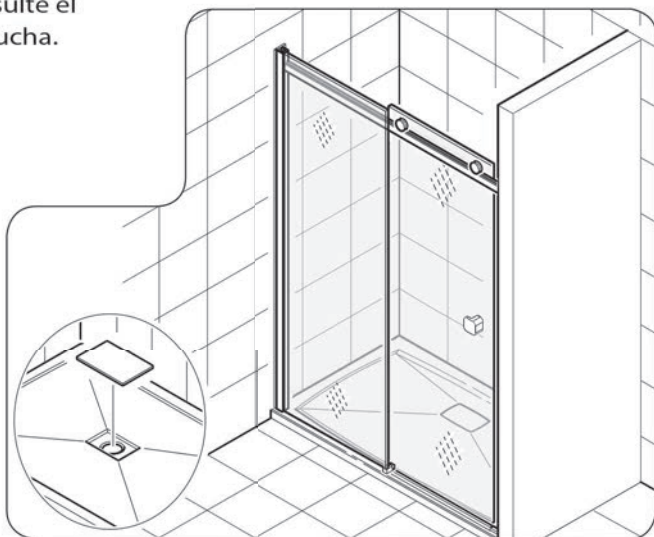



**SERVICE APRES-VENTE
ASSISTENZA POST-VENDITA
DIENST NA VERKOOP
ASISTENCIA POSTVENTA**



CE

FRANCE

N°Azur 0 810 05 1998
prix d'un appel local

UK

020 8842 0033

IRELAND

04697 33102

DEUTSCHLAND

0800 82 27 82 0

ITALIA

(0382) 6181

ÖSTEREICH

(0222) 21 402 16 0

SCHWEIZ

(01) 748 17 44

ESPAÑA

93 544 60 76

NEDERLAND

0475 487 100

BELGIË

+31 475 487 100

BELGIQUE

+31 475 487 100

РОССИЯ

963 19 40, 773 67 22